

Z50

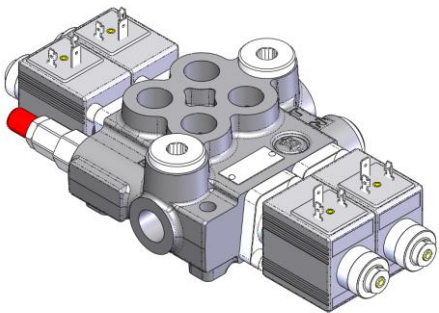
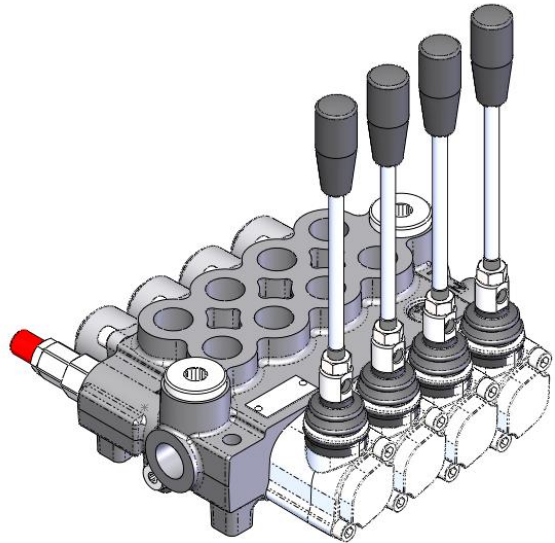
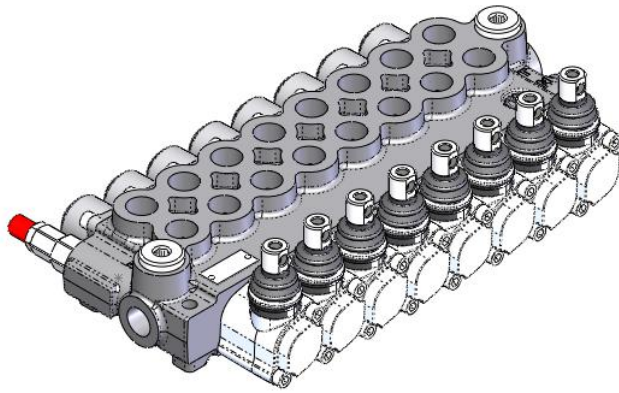
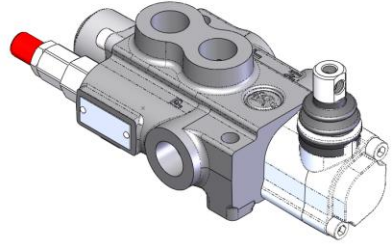
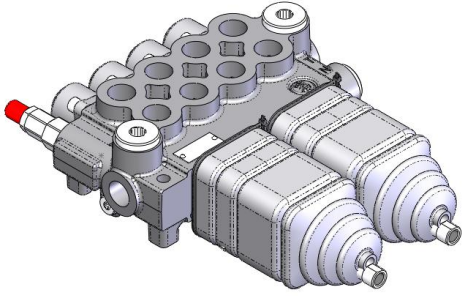

Z50

Simple compact and heavy duty designed monoblock from 1 to 8 sections for open and closed centre hydraulic systems.

- Fitted with a main pressure relief valve and a load check valve (individual check valve per spool – maximum 4 spools).
- Available with parallel and tandem circuit (only on 2, 3 and 4 spool valves)
- Optional power beyond port for parallel and tandem circuit
- Diameter 16 mm *0.63 in* interchangeable spools.
- A wide variety of options
- Floating spools and kits, regenerative spools and kits **do not** require additional machining on the body
- Actuation – manual, pneumatic, electro-pneumatic, hydraulic, electro-hydraulic, with solenoid and remote with flexible cable spool control kits.

Additional information

This catalogue shows the product in the most standard configuration. For special requests please contact sales.

WARNING!

All specifications of this catalogue refer to the standard product at this date. Badestnost, oriented to continuous improvement, reserves the right to discontinue, modify or revise specifications without notice.

Working conditions

Nominal flow rating		50 l/min	13.2 US gpm
Operating pressure (max.)	<i>parallel and tandem</i>	315 bar	4600 psi
Back pressure (max.)		35 bar	508 psi
Internal leakage (min.) A(B) to T	$\Delta p = 100 \text{ bar (1450 psi)}$ fluid and valve at 40 °C (104 °F)	7 cm ³ /min	0.42 in ³ /min
Hydraulic fluid		Mineral based oil	
Fluid temperature	<i>with NBR seals</i>	from -20 °C to 80 °C	from -4 °F to 176 °F
	<i>with FPM (Viton) seals</i>	from -20 °C to 100 °C	from -4 °F to 212 °F
Viscosity	<i>operating range</i>	from 15 to 75 mm ² /s	from 15 to 75 cSt
	<i>min.</i>	12 mm ² /s	12 cSt
	<i>max.</i>	400 mm ² /s	400 cSt
Permissible degree of fluid contamination		-/19/16 - ISO 4406	NAS 1683 - class 10
	<i>with mechanical devices</i>	from -40 °C to 60 °C	from -40 °F to 140 °F
Ambient temperature	<i>with pneumatic and hydraulic devices</i>	from -30 °C to 60 °C	from -22 °F to 140 °F
	<i>with electric devices</i>	from -20 °C to 50 °C	from -4 °F to 140 °F

Standard threads

	Reference standard			
	BSP	UN-UNF	Metric	NPTF
Thread according to	ISO 228/1	ISO 263	ISO 262	Ansi B1.20.3
Cavity dimension according to	BS 2779	ANSI B1.1 unified		
Cavity dimension according to	ISO 1179	11926	9974-1	
	SAE	J1926	J2244	J476a
	DIN 3852-2 (Shape X or Y)		3852-1 (Shape X or Y)	

Port threadings and codes

Codes:	G	G38	G12	S	S8	M
Main ports	BSP	BSP	BSP	UN-UNF	UN-UNF	Metric
Inlet P and outlet T	G1/2	G3/8	G1/2	7/8-14 (SAE10)	3/4-16 (SAE8)	M22x1.5
Working ports A and B	G3/8	G3/8	G1/2	3/4-16 (SAE8)	3/4-16 (SAE8)	M18x1.5
Control pilot ports						
Pneumatic	1/8-27 NPTF	1/8-27 NPTF	1/8-27 NPTF	1/8-27 NPTF	1/8-27 NPTF	1/8-27 NPTF
Hydraulic	G1/4	G1/4	G1/4	9/16-18 (SAE6)	9/16-18 (SAE6)	G1/4

Hydraulic circuits

Standard configuration – parallel body, common check valve (available 1 to 8 spools)

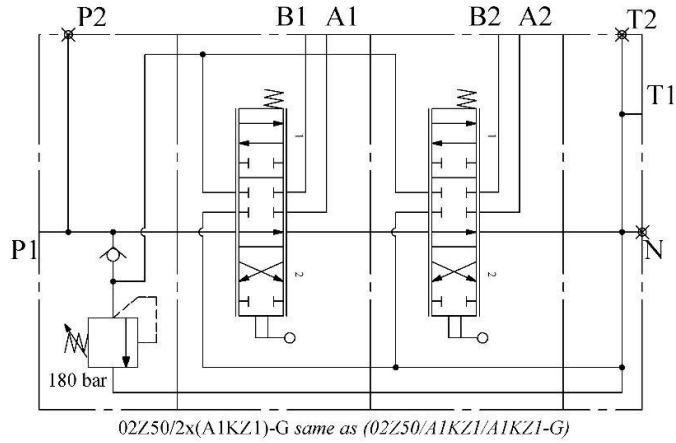

Standard configuration – parallel body, individual check valve (available 2 to 4 spools)

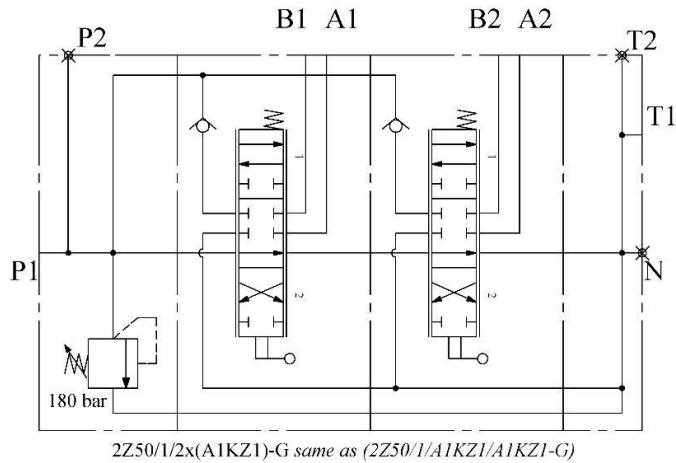

Standard configuration – tandem body, individual check valve (available 2 to 4 spools)

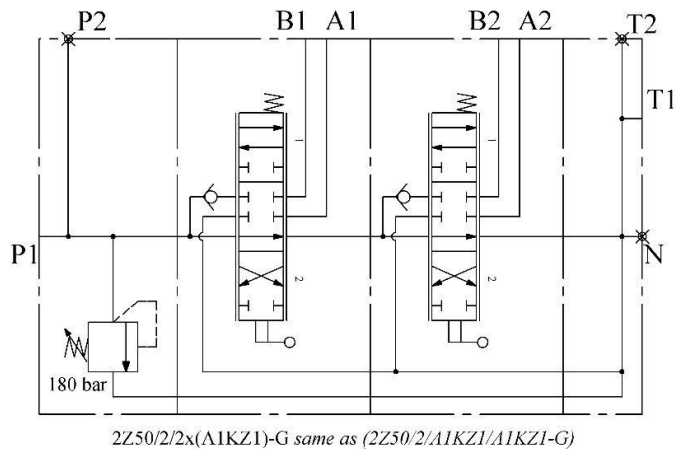

Performance data

Open centre

From side inlet to side outlet

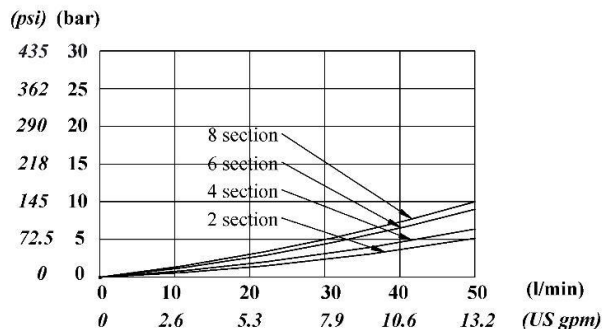
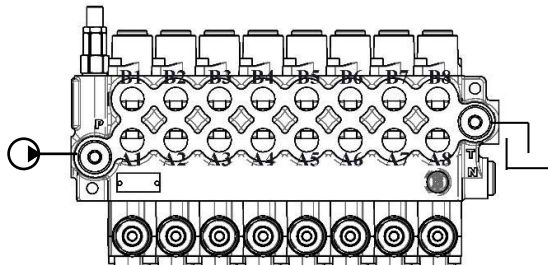

Inlet to work port

From side inlet to A port spool in position 2 or B port spool in position 1

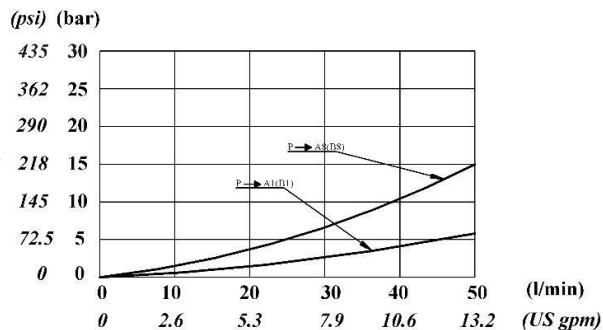
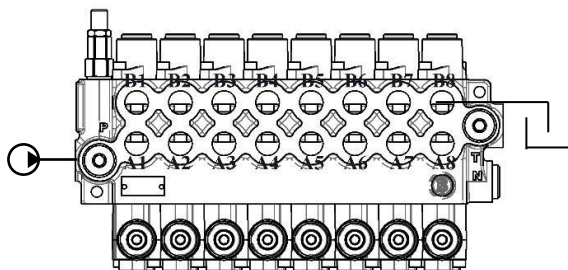

Work port to outlet

From A port spool in position 1 or B port spool in position 2 to side outlet

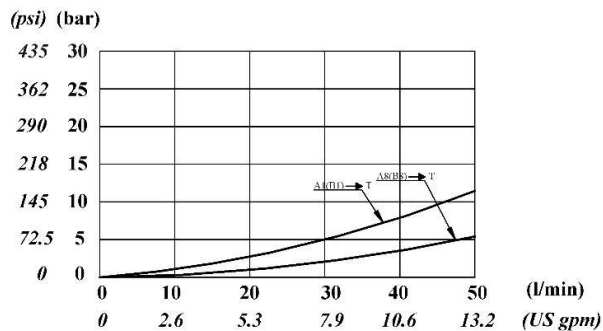
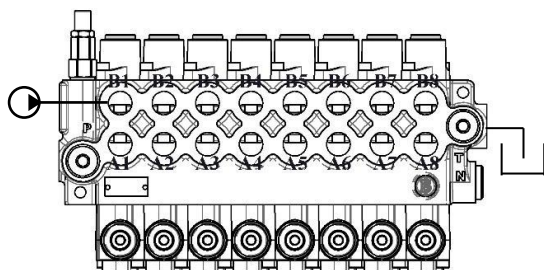

Dimensions

This drawing refers to a directional control valve with 2 working sections with common check valve (refer to next page for the body with individual check valves)

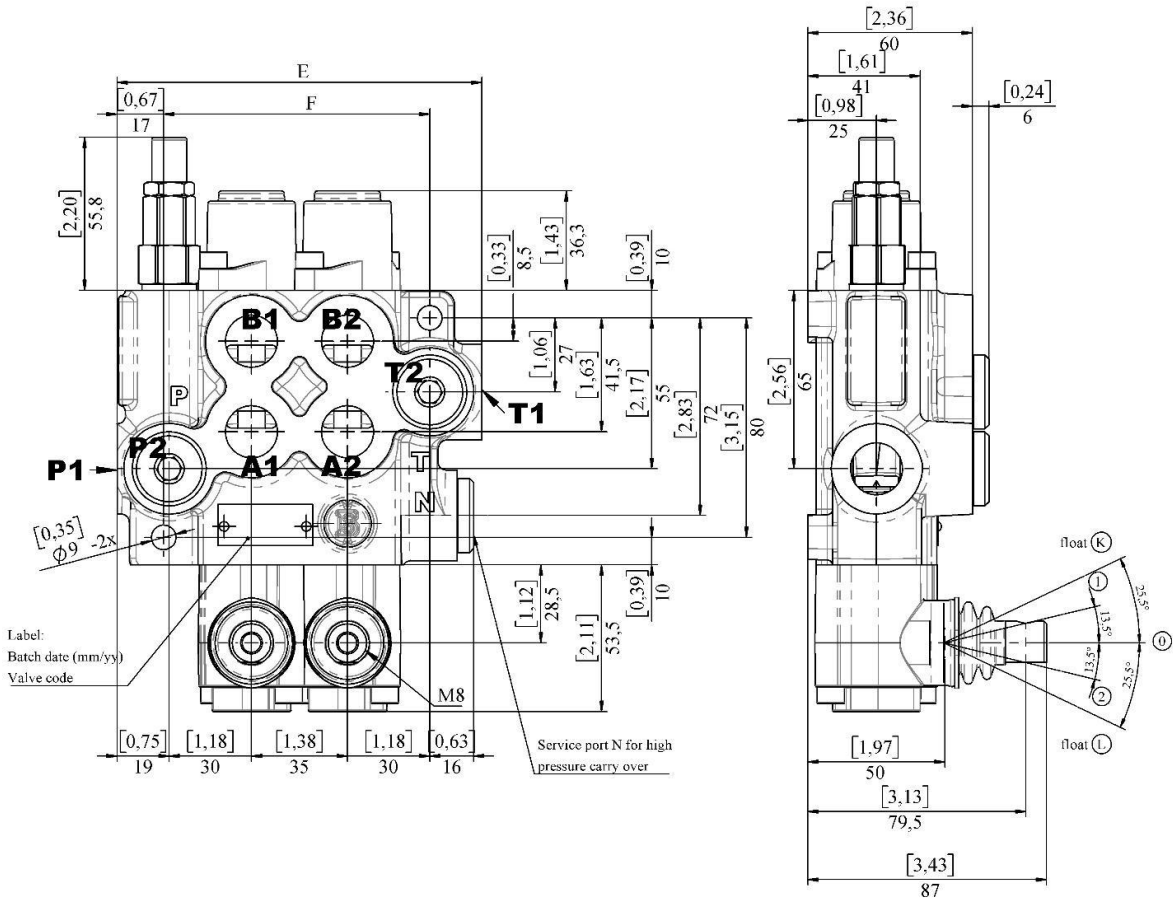

Float position L is shown just as a convention for direction, Z50 can have float- spool in **only** in right hand version – refer to page 20

TYPE	E		F		Weight	
	mm	in	mm	in	kg	lb
Z50	88	3.46	60	2.36	2.50	5.5
02Z50	133	5.24	97	3.82	4.10	9.0
03Z50	168	6.61	132	5.20	5.5	12.1
04Z50	203	7.99	167	6.6	6.90	15.2
05Z50	238	9.4	202	8.0	8.30	18.3
06Z50	273	10.7	237	9.3	9.70	21.4
07Z50	308	12.1	272	10.7	11.10	24.5
08Z50	343	13.5	307	12.1	12.50	27.6

Dimensions

This drawing refers to a directional control valve with 2 working sections with individual check valve per spool

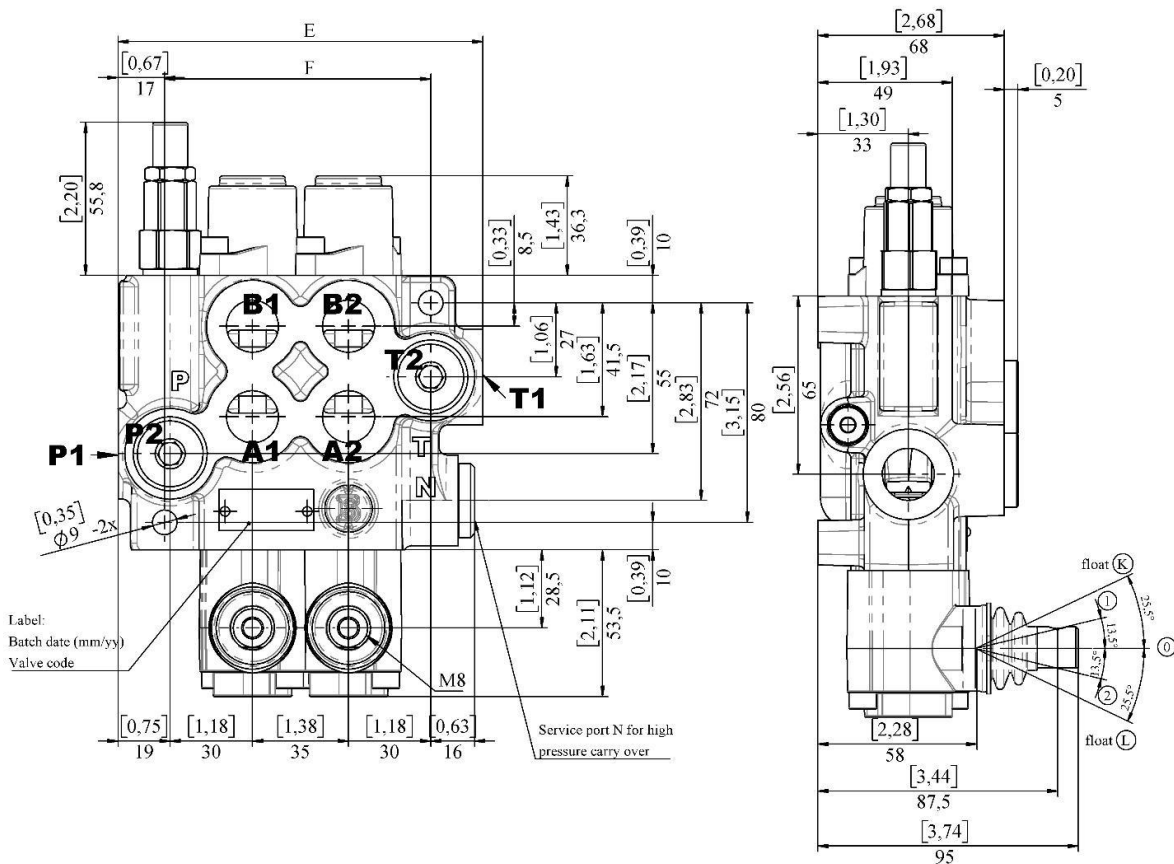

Float position L is shown just as a convention for direction, Z50 can have float- spool in **only** in right hand version – refer to page 20

TYPE	E		F		Weight	
	mm	in	mm	in	kg	lb
2Z50	133	5.24	97	3.82	4.10	9.0
3Z50	168	6.61	132	5.20	5.5	12.1
4Z50	203	7.99	167	6.6	6.90	15.2

Order code, complete

First section
Following sections

02Z50 (D4-280-FV)/A 1 KZ1/A ES3-12V(C)-C2 – G - Zn

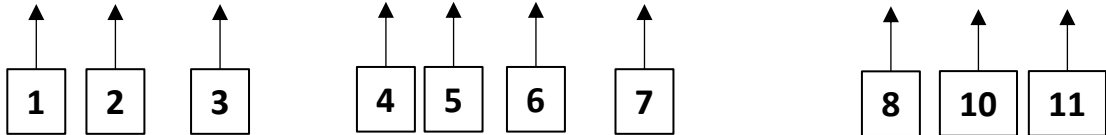

*For identical sections use quantity of sections x (code of section),
e.g. 2x(A1KZ1)...*

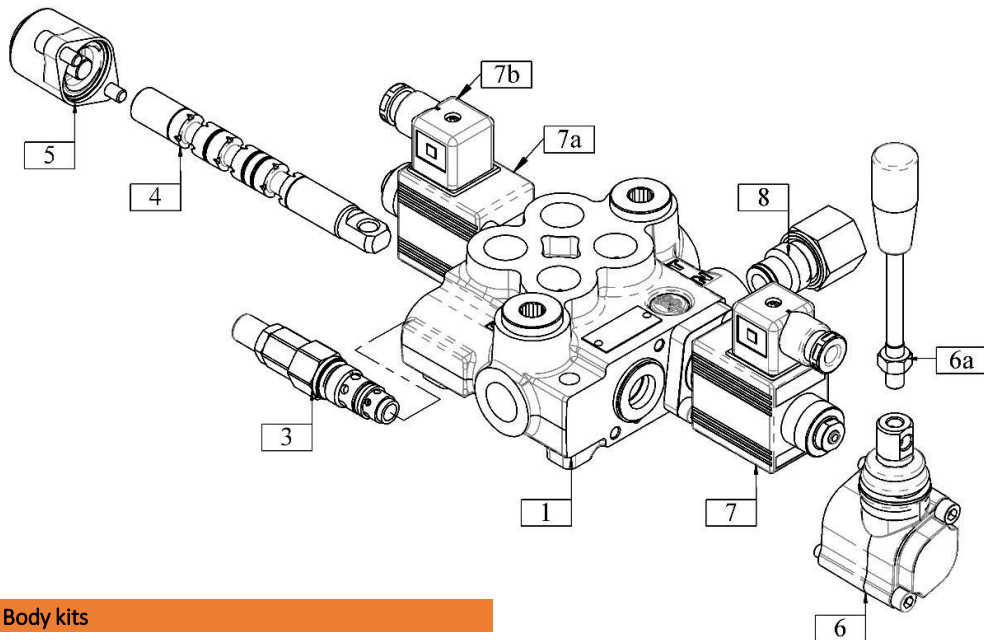

1 Body kits

Type	Description
Z50	Parallel, 1 section
02Z50	Parallel, 2 section, common check valve
03Z50	Parallel, 3 section, common check valve
04Z50	Parallel, 4 section, common check valve
05Z50	Parallel, 5 section, common check valve
06Z50	Parallel, 6 section, common check valve
07Z50	Parallel, 7 section, common check valve
08Z50	Parallel, 8 section, common check valve
2Z50/1/	Parallel, 2 section, individual load checks
3Z50/1/	Parallel, 3 section, individual load checks
4Z50/1/	Parallel, 4 section, individual load checks
2Z50/2/	Tandem, 2 section, individual load checks
3Z50/2/	Tandem, 3 section, individual load checks
4Z50/2/	Tandem, 4 section, individual load checks

2 Position with respect to pump inlet

omit	Left hand configuration, pump port is on the left hand side with respect to control
R	Right hand configuration, pump port is on the right hand side with respect to control

3 Inlet relief options

Type	Description
omit	Range 120-250 bar / 1740 to 3625 psi standard setting at 180 bar / 2610 psi
(D2-120)	Range 50-120 bar / 725 to 1740 psi standard setting at 120 bar / 1740 psi pressure range has to be always specified
(120-250)	Range 120-250 bar / 1740 to 3625 psi setting other than 180 bar / 2610 psi
(D4-220)	Range 220-315 bar / 3190 to 4570 psi standard setting at 220 bar / 3190 psi pressure range has to be always specified
(sok)	Without check valve
(svp)	Relief valve blanking plug
(FV)	Fixed valve setting and steel cap nut

Standard setting is referred to 12 l/min flow, example for relief valve with a preset valve at 250 bar with cap nut without check valve (D4-250-sok-FV)

Order code, continue

4 Spool options

Type	Description
A	Double acting, 3 position, with A and B closed in pos. 0
As	Double acting, 3 position, with A and B closed in pos. 0, fine metering
B	Single acting on A, 3 positions, B plugged, requires a plug.
C	Single acting on B, 3 positions, A plugged, requires a plug.
D	Double acting, 3 position, with A and B opened to tank in pos. 0
E	Double acting, 3 position, B opened to tank in pos. 0
F	Double acting, 3 position, A opened to tank in pos. 0
Dd	Double acting, 3 position, with A and B partially open to tank in pos. 0
Ed	Double acting, 3 position, B partially opened to tank in pos. 0
Fd	Double acting, 3 position, A partially opened to tank in pos. 0
M	Double acting, 3 position, blocked by-pass channel for closed center circuit
<i>Special spools for particular positioner kits</i>	
Us	Double acting, 4 positions, regenerative position in between pos. 0 and position 2, spool in
K	Double acting, 4 positions, floating circuit in 4th position with spool out, only available in left hand configuration
L	Double acting, 4 positions, floating circuit in 4th position with spool in, only available in right hand configuration

5 Spool positioners (side B)

Type	Description
1	With spring return in pos. 0
1C	With spring return in pos. 0, soft spring
1Z	With spring return in pos. 0 and pin with M8x1 male thread for dual control
1rAB	With spring return in pos. 0 and stroke adjustments both directions
1zS1	With spring return in pos. 0 and pin with M8 male thread for dual control
1D(M6)	With spring return in pos 0 and pin with M6 female thread for dual control
1E	With spring return in pos. 0, includes microswitch kit
14	Spring return in pos. 0, no microswitch kit included

14C	Spring return in pos. 0, soft spring, no microswitch kit included
4	2 positions, with spring return in pos. 0 from pos. 2
5	2 positions, with spring return in pos. 0 from pos. 1
6	2 positions, with spring return in pos. 1 from pos. 2
7	2 positions, with spring return in pos. 2 from pos. 1
7Z	2 positions, with spring return in pos. 2 from pos. 1 and pin with M8x1 male thread for dual control
7T	2 positions, with spring return in pos. 2 from pos. 1 with teton (push piston)
7D(M6)	2 positions, with spring return in pos. 2 from pos. 1, and pin with M6 female thread for dual control
7zS1	2 positions, with spring return in pos. 2 from pos. 1 with special tie rod kit M8 for dual control
8	Detent in positions 0, 1 and 2
8Z	Detent in positions 0, 1 and 2, and pin with M8 male thread for dual control
9	Detent in positions 1 and 0
10	Detent in positions 0 and 2
11	Detent in positions 1 and 2
11B	Detent in positions 1 and 2, and spring return to pos. 0
2	With detent in position 1 and spring return in pos. 0
3	With detent in position 2 and spring return in pos. 0
1V2	With spring return in pos. 0 for flexible cable control
8V2	Detent in positions 0, 1 and 2 for flexible cable control
1H	Proportional hydraulic control- single side
1P	ON/OFF pneumatic control
1EP	ON/OFF electro-pneumatic control
1ED3	ON/OFF electro-hydraulic control
<i>Particular positioner kits for special spools</i>	
17	4 position with spring return to pos. 0 from pos. 2, soft stop at (regenerative) before pos. 2 and detent in pos. 1
12	4 position with spring return in pos. 0 and detent in float position - only for spool L
13	Detent in 4 positions - only for spool L
16	4 position with spring return in pos. 0 and detent in float position - only for spool K
15	Detent in 4 positions - only for spool K

Order code, continue

6	Spool controls (side A)
	<i>without lever box, with plate</i>
KZ	<i>Lever box for M8</i>
KZ(M10)	<i>Lever box for M10</i>
KZT	<i>Lever box for M8 with teton (push piston)</i>
KI	<i>Lever box, collet type, horizontal Ø9 mm</i>
KY	<i>Lever box, collet type, vertical Ø9 mm</i>
KZ(rA)	<i>Lever box, with stroke limiter</i>
KZe	<i>Lever box for M8, extreme conditions</i>
KZe(M10)	<i>Lever box for M10, extreme conditions</i>

Adding a **0** after the first part of the code will make the execution rotated 180°, lever will face the bottom of the valve, not the ports eg. **KZ0**

KZV	<i>Safety lever box, vertical configuration</i>
KZH	<i>Safety lever box, horizontal configuration</i>
SLP	<i>without lever box with dustproof plate</i>
V1	<i>Flexible cable connection</i>
ju+1	<i>Joystick lever for 2 sections with pivot above right, standard cylindrical handle</i>
ju+2	<i>Joystick lever for 2 sections with pivot above left, standard cylindrical handle</i>
ju+3	<i>Joystick lever for 2 sections with pivot bottom left, standard cylindrical handle</i>
ju+4	<i>Joystick lever for 2 sections with pivot bottom right, standard cylindrical handle</i>

Optional ball type handle (jb+...), and custom lengths

6a	Handle options
1	<i>Depending on lever kit M8x150 or M10x170</i>

Custom lengths and bends available

7	Complete controls
1ESD	<i>Double acting solenoid kit, standard version with lock/unlock lever kit K1</i>
ES	<i>Single acting solenoid kits - ES3/ES2/ES1</i>
A26	<i>Control with rotation (CW-CCW)</i>

7a	Coil specifications
12V	<i>12V coil, for ISO4400 connector</i>
24V	<i>24V coil, for ISO4400 connector</i>
12V(DT)	<i>12V coil, for Deutsch connector</i>
24V(DT)	<i>24V coil, for Deutsch connector</i>

Exact coil specifications follow in the catalog

7b	Connectors
omit	<i>By default connectros are not included, except in 1ESD control and electro-pneumatic control 1EP</i>
(C)	<i>Connector for the particular coil is included</i>

8	Outlet port options
omit	<i>BSP G1/2 plug on port N</i>
C	<i>Closed center plug</i>

C2	<i>For BSP threading - G1/2 high pressure carry-over sleeve</i>
C2(38)	<i>For BSP threading - G3/8 high pressure carry-over sleeve</i>
C2(S)	<i>For SAE threading - SAE10 high pressure carry-over sleeve</i>
C2(NPTF)	<i>For NPTF threading - 1/2NPTF high pressure carry-over sleeve</i>
C2D	<i>High pressure carry-over kit, direct connection</i>
VRE	<i>Back pressure valve</i>

9	Inlet outlet selection
omit	<i>Side inlet, side outlet, others plugged</i>
22	<i>Top inlet, top outlet, others plugged</i>
12	<i>Side inlet, top outlet, others plugged</i>
21	<i>Top inlet, side outlet, others plugged</i>

10	Valve Threading - refer to page 3
-----------	--

11	Coating and plating
omit	<i>Valve body is phoshpated, steel parts zinc plated, spools either Ni, or Cr plating (omit in valve description)</i>
Zn	<i>Valve body - Zinc plated</i>
BP	<i>Painting, standard black, others optional</i>

Inlet relief options

D4-280-sok-FV

(FV) - Steel cap nut for pre-set pressure
 (sok) – without load check valve
 Pressure setting, if not specified – standard pressure setting per spring (p.8)
 Adjustable spring type (2 and 4)
 Pressure setting within the range 120-250 bar / 1740 to 3625 psi, by default uses spring no.3 and does not require to be specified in the ordering code e.g. (150)

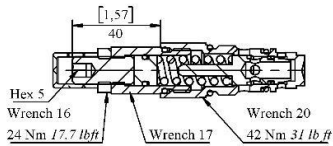

Note: Check valve is not shown

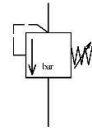
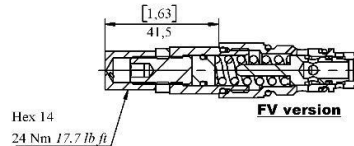

svp– relief valve blanking plug

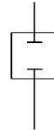
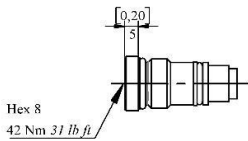

Relief valve type “D” performance characteristics

Spring nr. 2

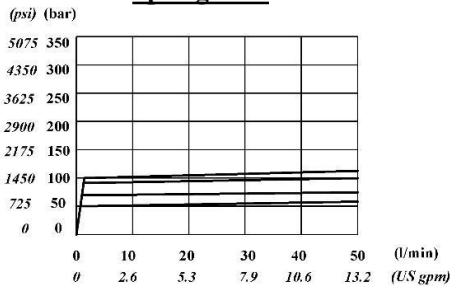

Spring nr. 4

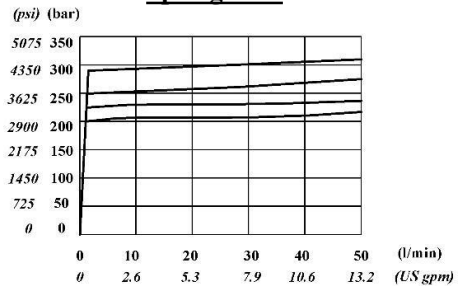

Spring nr. 3

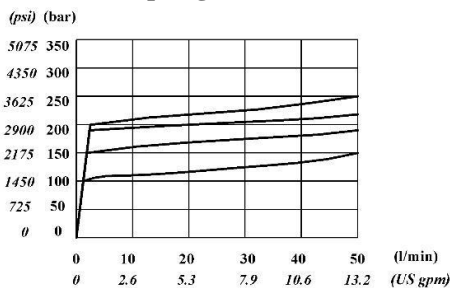

Time response

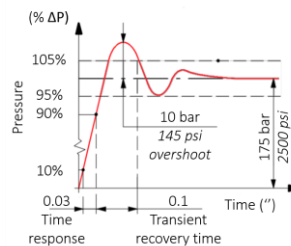

Spool options:

Badestnost standard spool have the end shown in the drawing below.

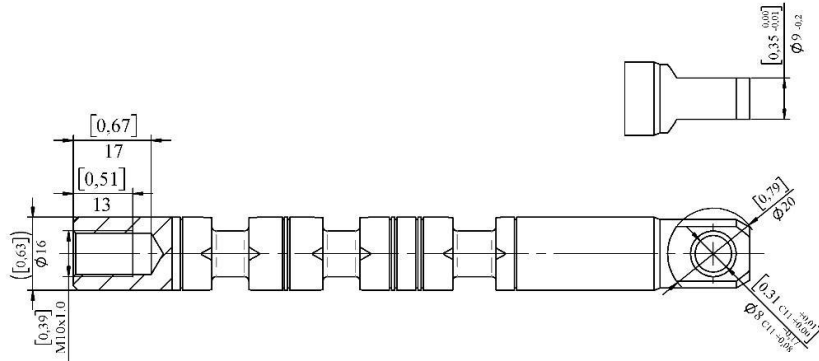

Double acting spools

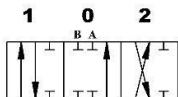

A Double acting spool, work ports closed in neutral position.

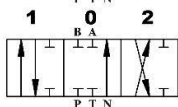
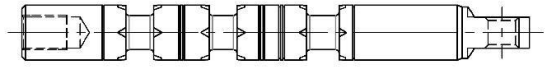

As Double acting spool, high metering, work ports closed in neutral position.

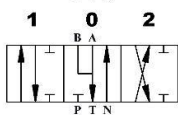
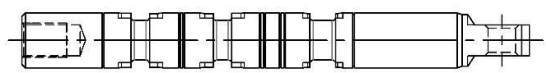

D Double acting spool, work ports open to tank in neutral position.

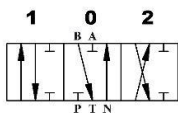
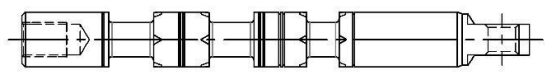

E Double acting spool, work port B open to tank in neutral position.

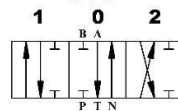
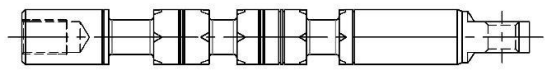

F Double acting spool, work port A open to tank in neutral position.

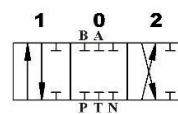
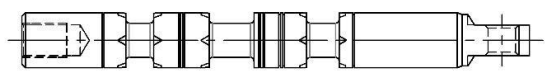

M Double acting spool, closed center, work ports closed in neutral.

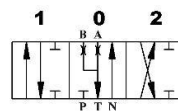
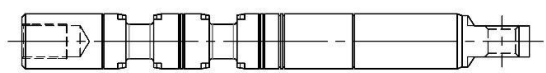

Dd Double acting spool, closed center, work ports partially open to tank

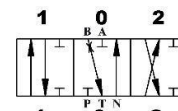
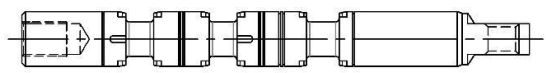

Ed Double acting spool, closed center, work port B partially open to tank

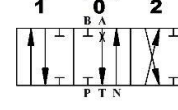
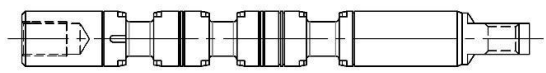

Fd Double acting spool, closed center, work port A partially open to tank

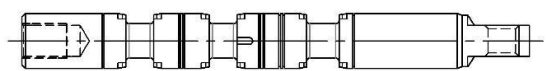

Spool options, continue

Single acting spools

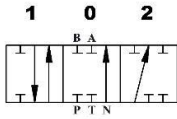

B

Single acting on A, 3 position, B plugged

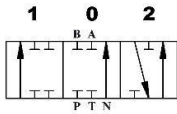
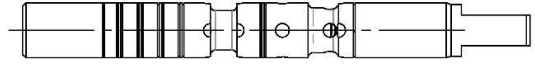

C

Single acting on B, 3 positions, A plugged

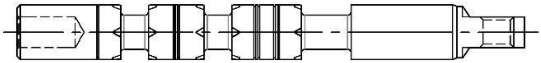

Regenerative spools

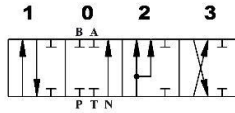

Us

Double acting, 4 positions, regenerative position

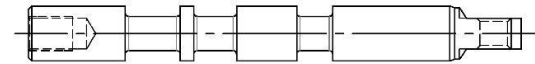

Spool U requires spool positioner - 6 or 17, and it is available to valves ONLY with left hand configuration (P on left with respect to lever control)

Floating spools

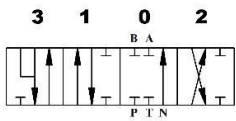

K

Double acting, 4 positions, floating circuit in 4th position with spool out

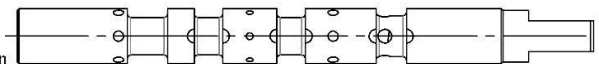

Spool K requires spool positioner - 16 or 15, and it is available to valves ONLY with left hand configuration (P on left with respect to lever control)

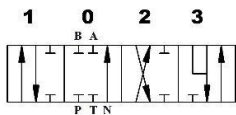

L

Double acting, 4 positions, floating circuit in 4th position with spool in

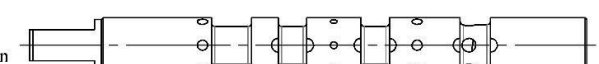

Spool L requires spool positioner - 12 or 13, and it is available to valves ONLY with "R" right hand configuration (P on right with respect to lever control)

All spools have "R" version for right version of the valve, exceptions are Us, K and L.

To order right hand version of a spools, add "R" behind the spool description e.g. AR, BR, CR, etc.

To order low leakage version of spools, add "n" behind the spool description e.g. An, Bn, Cn, etc.

Spool positioners (B-side)

Kit 1

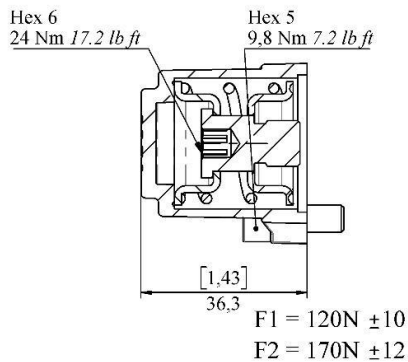
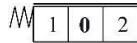

Kit 1C

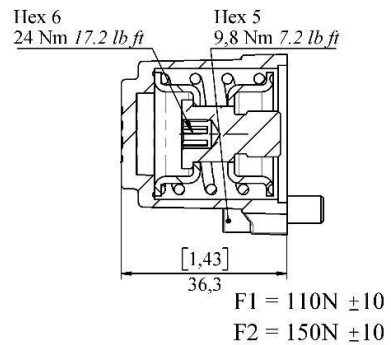

Kit 1Z

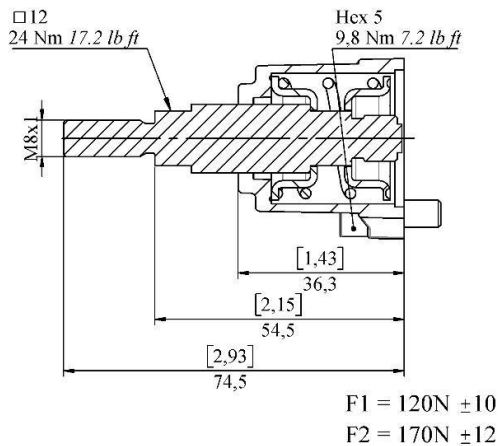
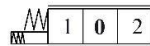

Kit 1zS1

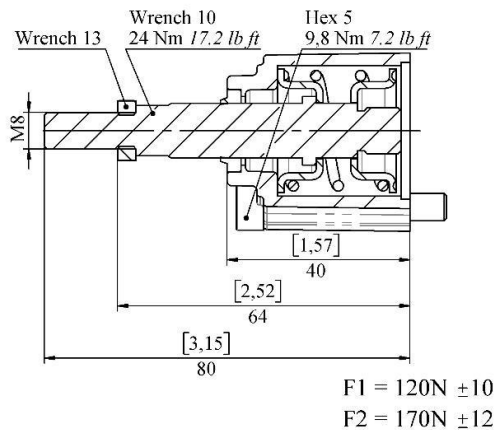
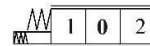

Kit 1D(M6)

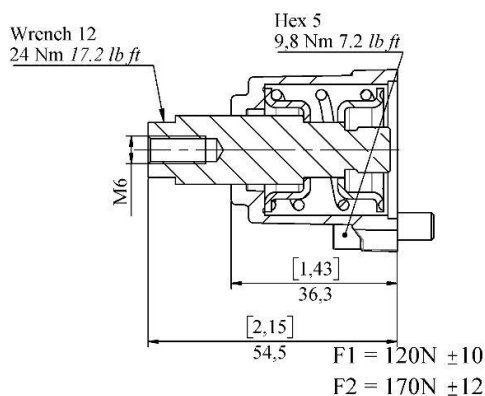
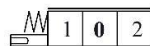

Kit 1rAB

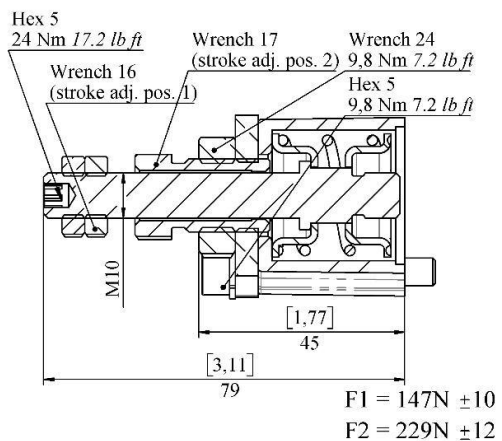
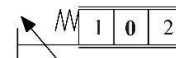

Spool positioners (B-side)

Kit 4

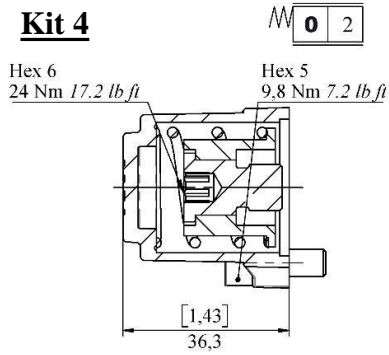

Kit 5

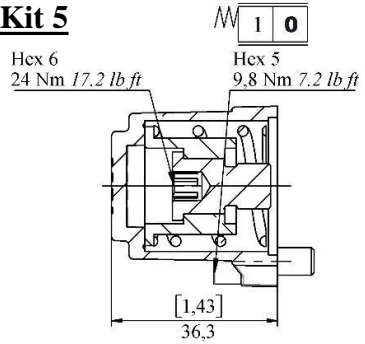

Kit 6

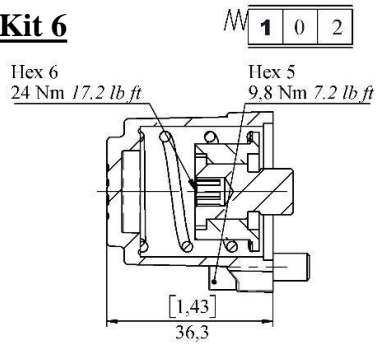

Kit 7

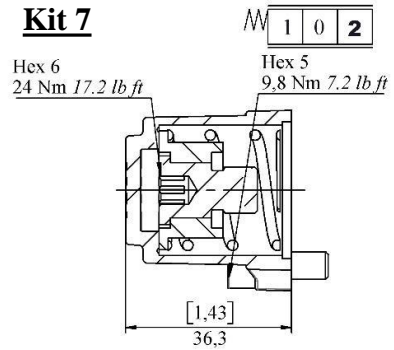

Kit 7T

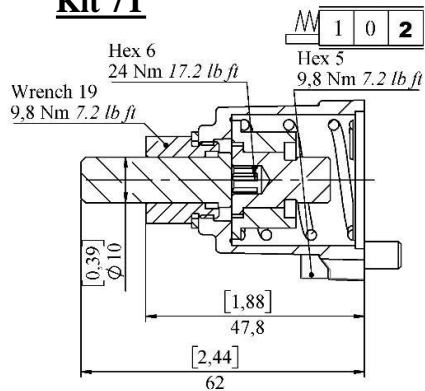

Kit 7D(M6)

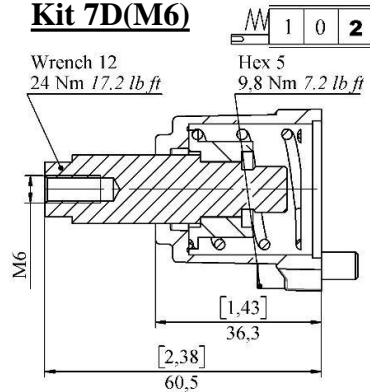

Spool positioners (B-side)

Kit 7Z

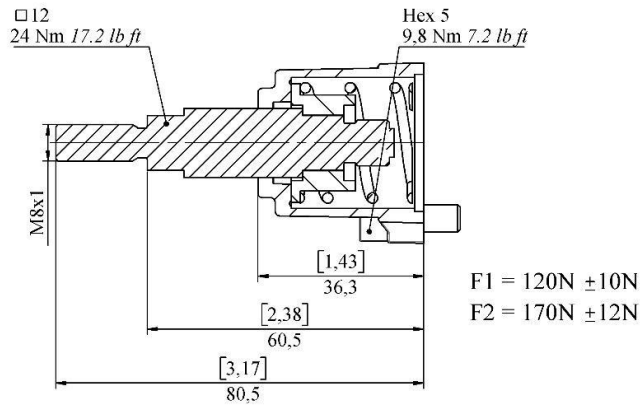
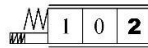

Kit 7zS1

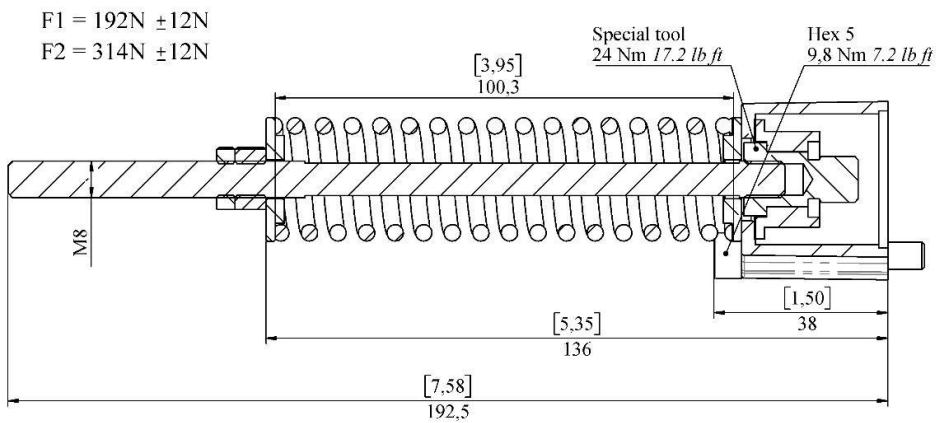
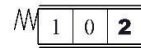

Particular kits for regenerative spool Us

Kit 17

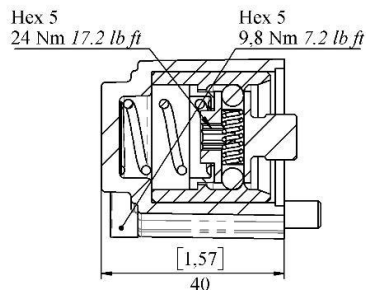
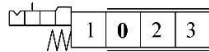

Kit 6 (Us)

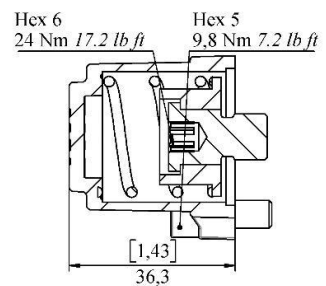
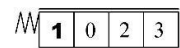

Spool positioners (B-side)

Kit 8

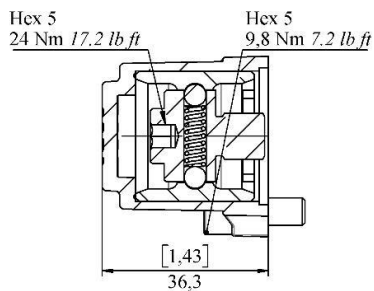
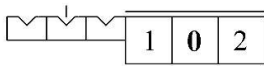

Kit 8Z

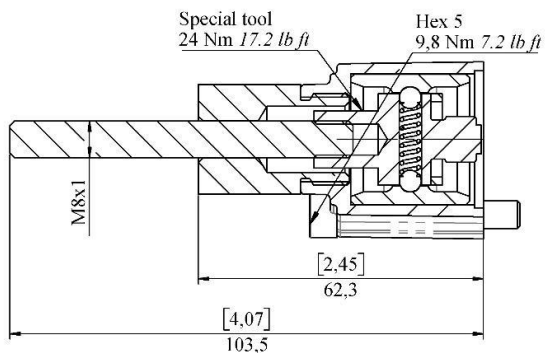
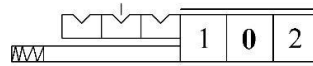

Kit 9

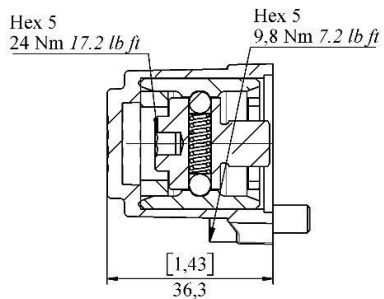
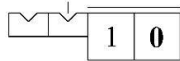

Kit 10

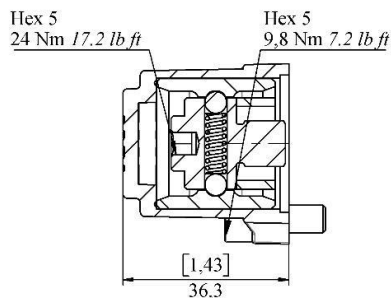

Kit 11

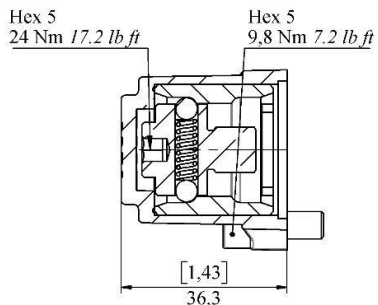
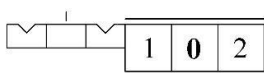

Spool positioners (B-side)

Kit 2: 3 position, spring return from pos. 2 to pos. 0 and detent in pos. 1

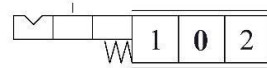
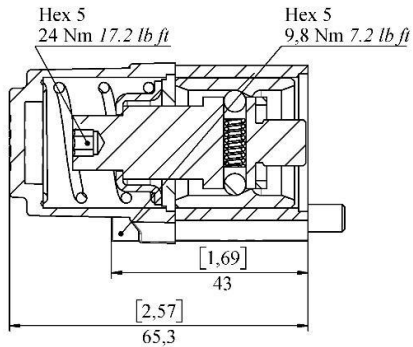

Kit 3: 3 position, spring return from pos. 1 and detent in pos. 2

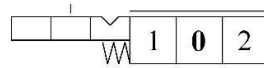
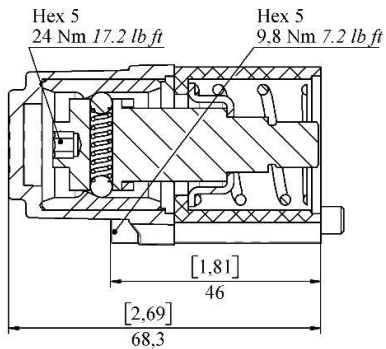

Kit 11B: 2 position, with detent in both positions and spring return to neutral from either direction

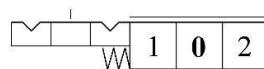
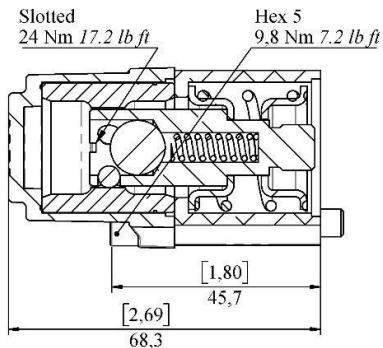

Particular spool positioners kits for floating spool K (float when spool OUT)

Kit 16: *four position, return to neutral from 1 and 2 and detent in float*

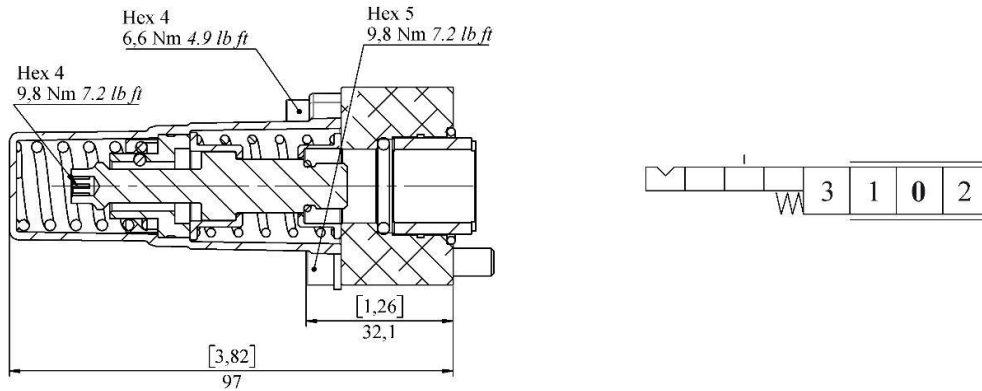

Kit 15: *four position detent*

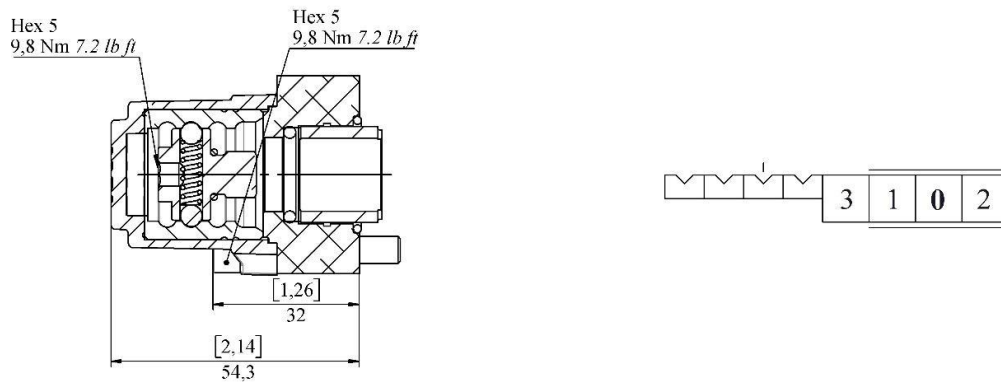

Limitations of floating sections for Z50

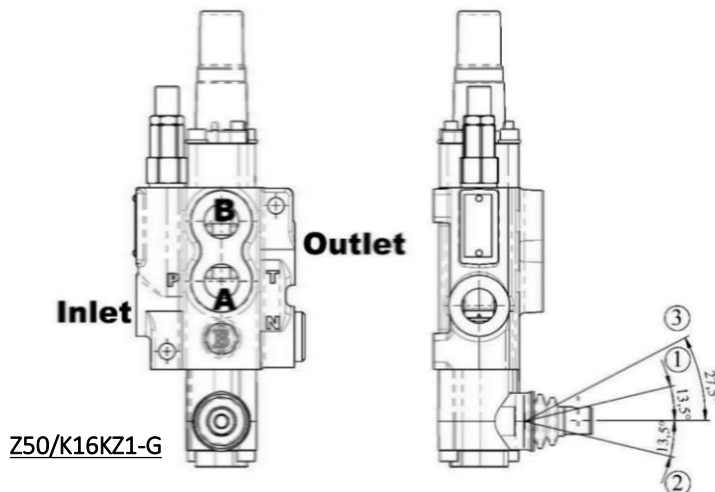

Floating spool OUT (K16 and K15) can be used only on standard configuration with left inlet (with respect to the lever)

Particular spool positioners kits for floating spool L (float when spool IN)

Kit 12: four position, return to neutral from 1 and 2 and detent in float

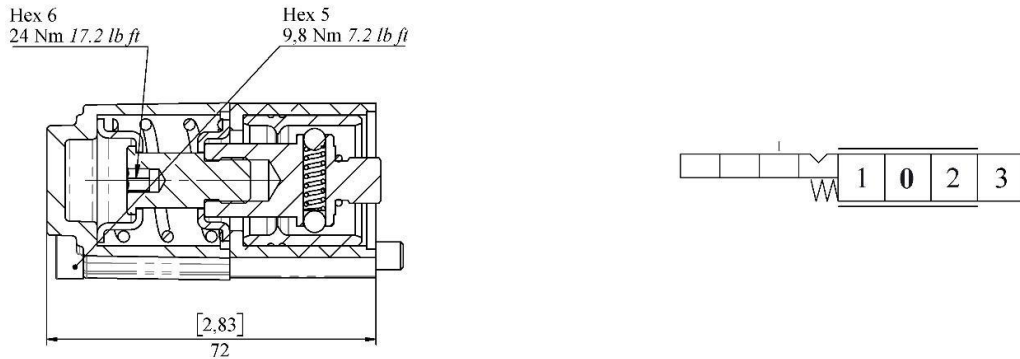

Kit 13: four position detent

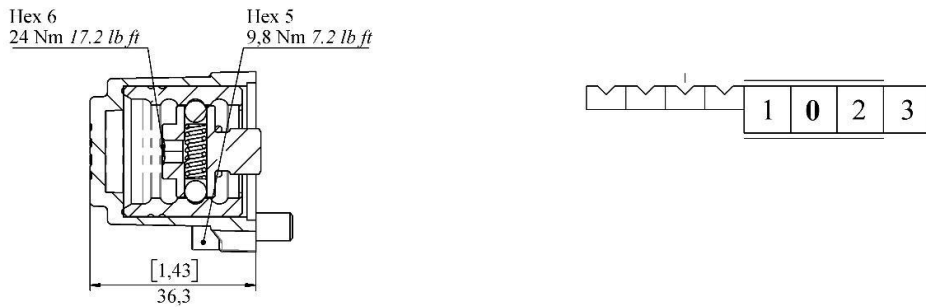

Limitations of floating sections for Z50

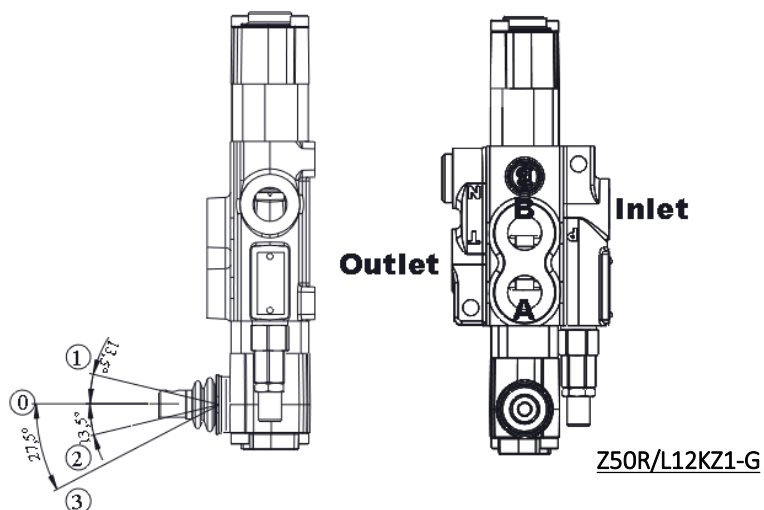

Floating spool IN (L12 and L13) can be used only on “R” configuration valve with right inlet (with respect to the lever)

Particular spool positioners kits for microswitch

Kit 1E for double acting spool A or D

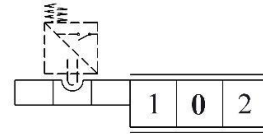
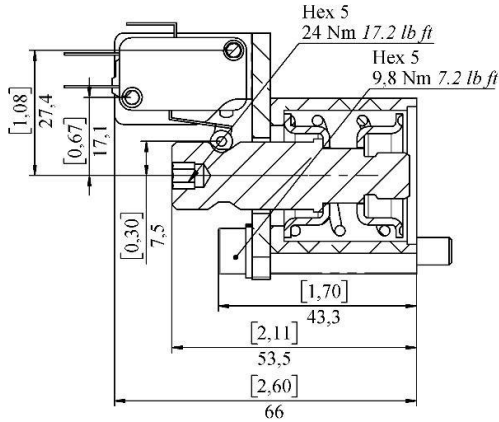

For double acting spool A

Kit 1E for single acting spool B

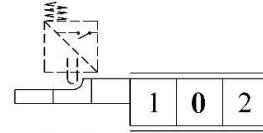
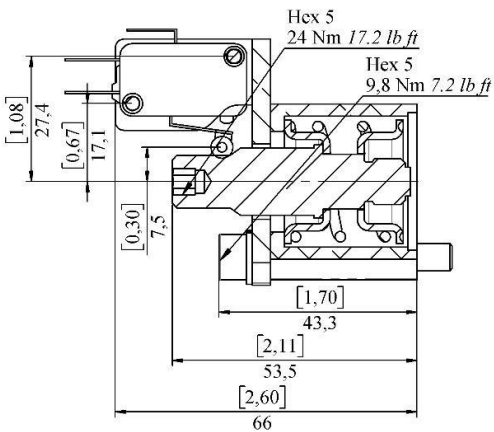

For single acting spool B

Kit 1E for single acting spool C

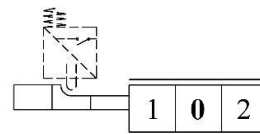
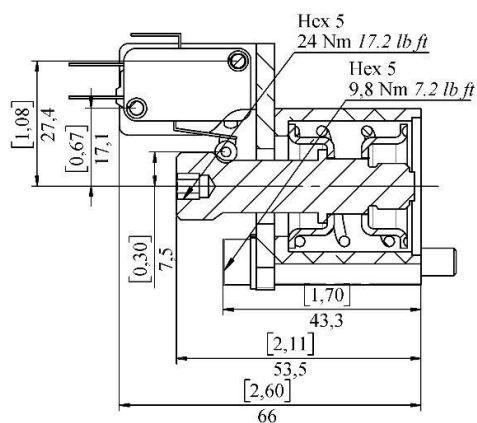

For single acting spool C

Microswitch specification for spool positioner 1E

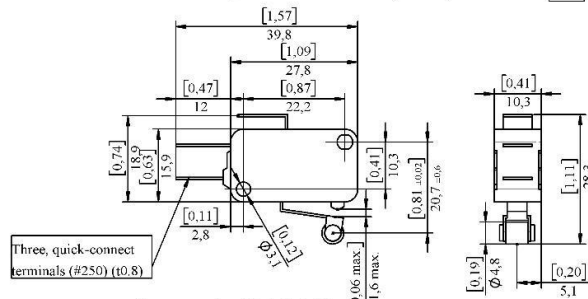

Omron code - V-165-1C5

Needs a special bracket to be assembled with spool positioners

Spool positioner for flexible cable connection (side B)

Kit 1V2

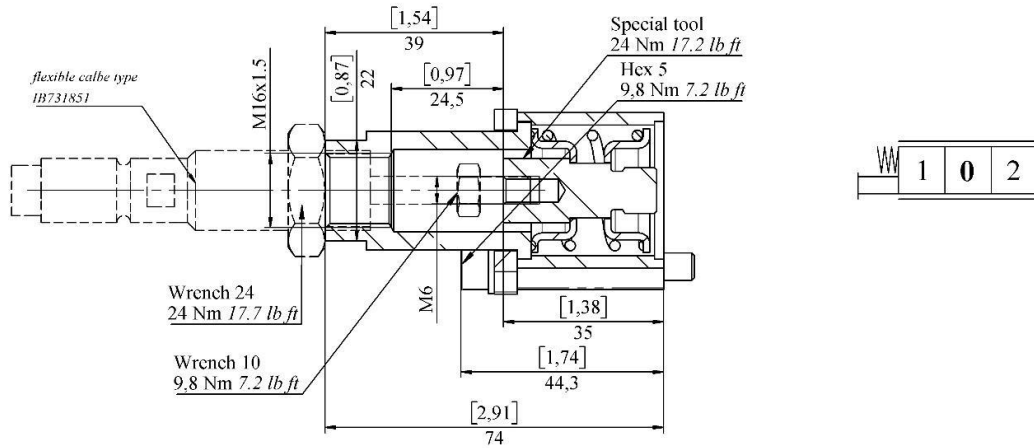

Kit 8V2

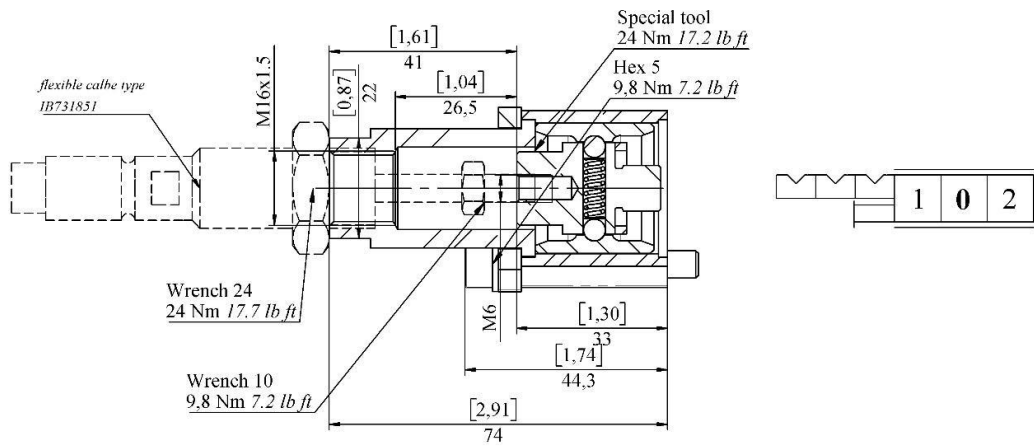

More information regarding controls, cable lengths, and ordering codes see page for flexible cable control V1 (Side A)

ON/OFF Pneumatic kit - 1P

With spring return to neutral position

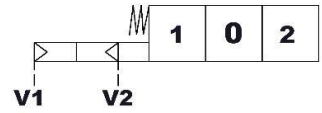
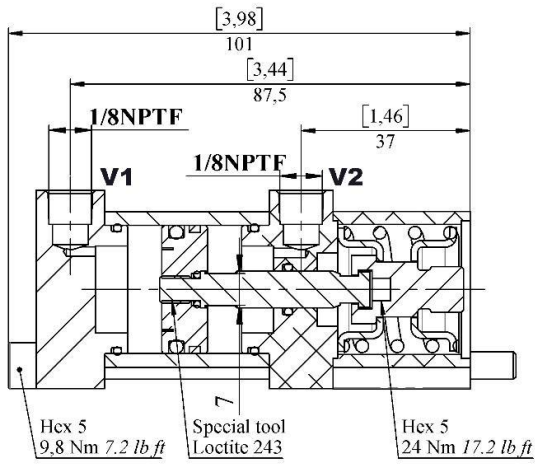

Operating features

Pilot pressure	min	5,5 bar / 73 psi
	max.	10 bar / 145 psi

ON/OFF Electro pneumatic kit – 1EP

With spring return to neutral position

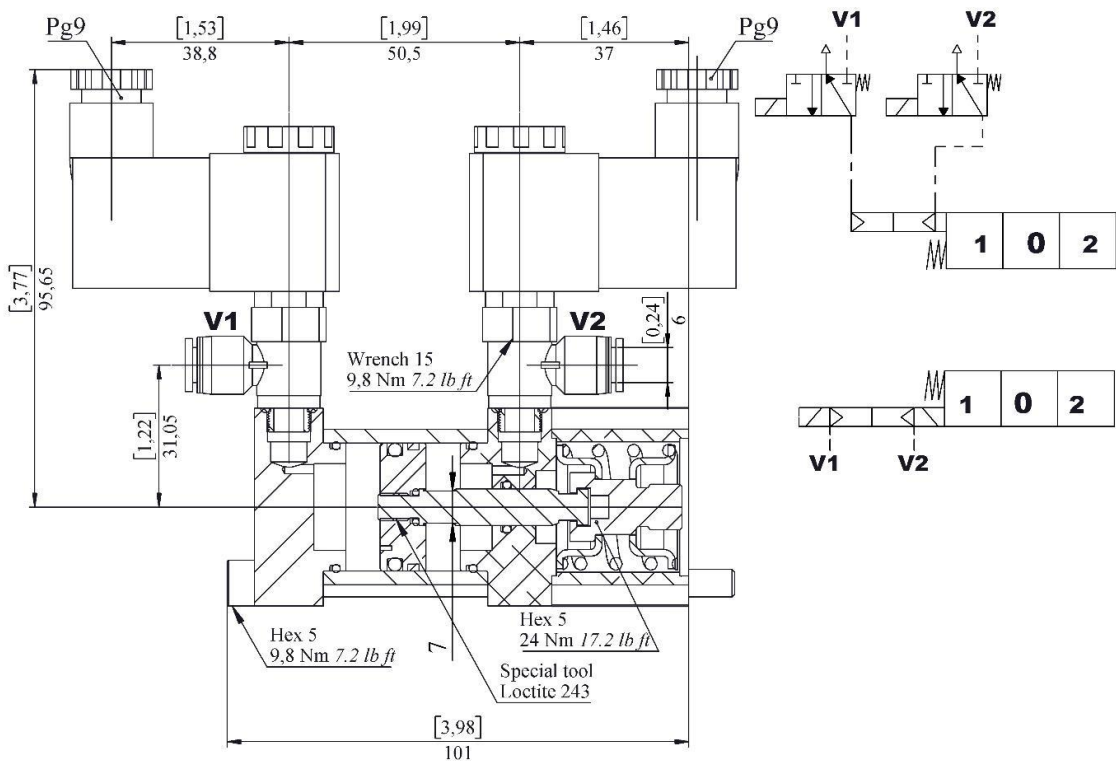

Connector specifications:

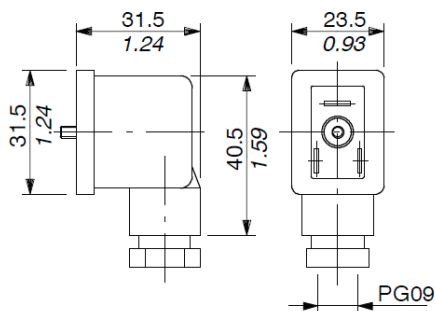

Operating features

Pilot pressure	min	5,5 bar / 73 psi
	max.	10 bar / 145 psi

COIL specifications

Nominal voltage tolerance	±10 %
Power rating	4,8 W
Nominal current	0,4 A - 12 VDC
	0,2 A - 24 VDC
Coil insulation	Class F
Weather protection	IP65
Duty cycle	100%

Connector is always included in 1EP control

Proportional hydraulic, single side kit - H

With spring return to neutral position

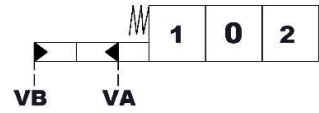
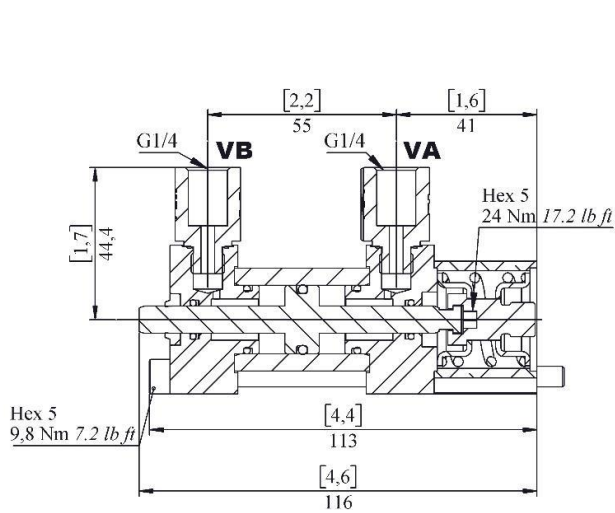

Operating features
Pilot pressure max. 50 bar / 725 psi

Pilot pressure - stroke diagram

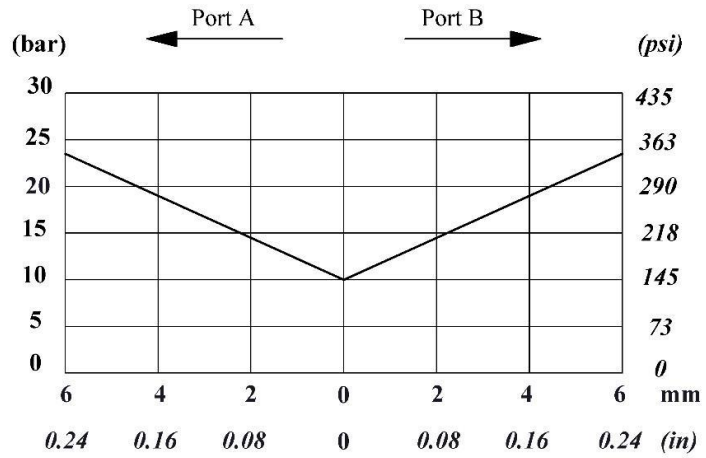

ON/OFF electro-hydraulic kit - 1ED3

With spring return to neutral position

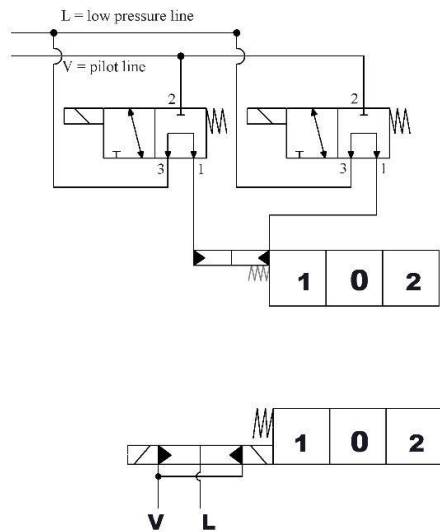
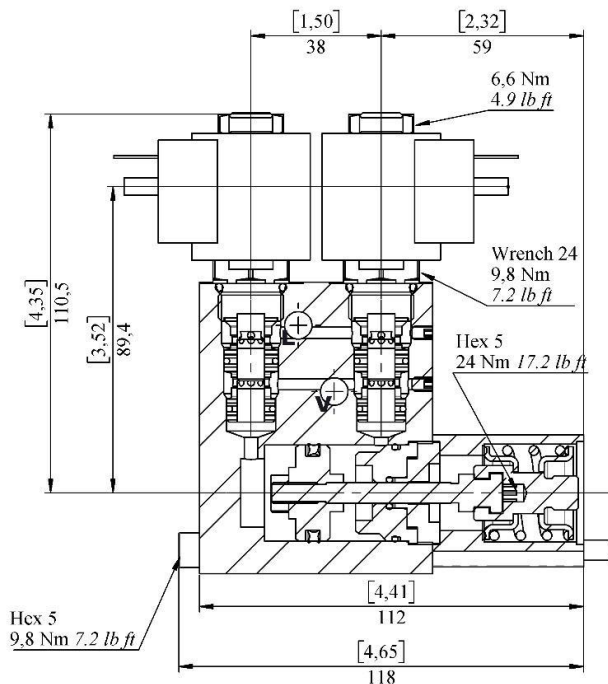

Connector specifications 2 poles, type Deutsch DT06-2S Male housing with female ends

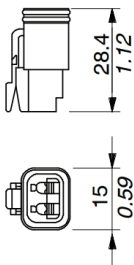

Connector specifications 2P+T according to ISO 4400 / EN175301-803

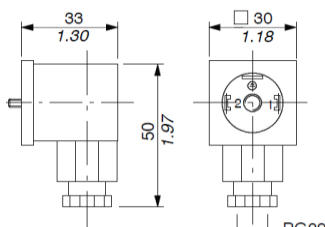

Operating features

Pilot pressure	min	10 bar / 145 psi
	max.	50 bar / 725 psi
Back pressure on drain L	max.	25 bar / 360 psi

COIL specifications

Nominal voltage tolerance	±10 %
Power rating	21 W
Nominal current	1,75 A - 12 VDC
	0,87 A - 24 VDC
Coil insulation	Class F
Weather protection	IP65
Duty cycle	100%

ON/OFF electro-hydraulic kit - 1ED3 with external drain

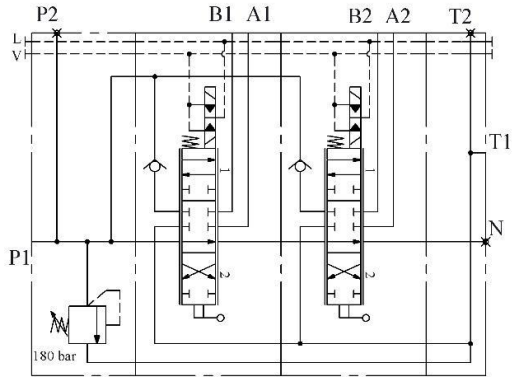
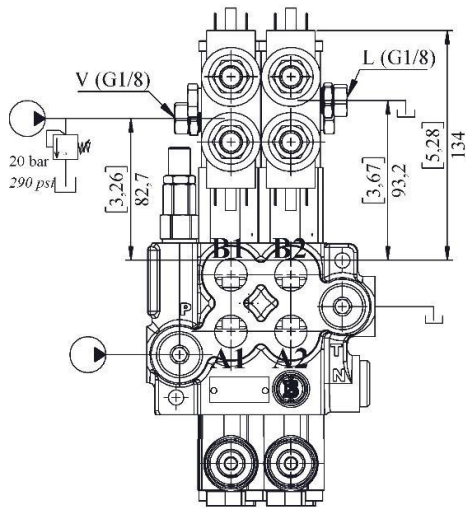

Description example:

2Z50/1/2x(A1ED3KZ1)-12V-G

ON/OFF electro-hydraulic kit - 1ED3 with pilot and drain lines

Kit consists of pressure reducing valve, VRP, back pressure valve VRE and pipes

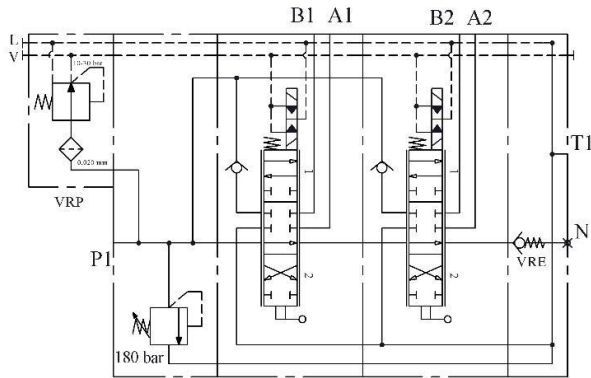
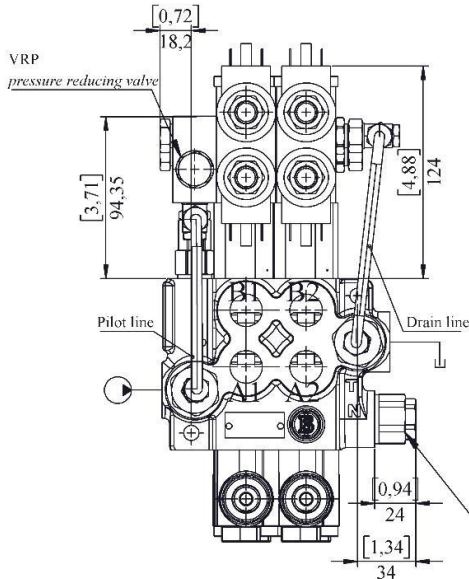

Description example:

2Z50/1/VRP/2x(A1ED3KZ1)-VRE-12V-G

Back pressure valve (VRE) specifications

Valve is assembled on the bypass flow port N to provide pilot pressure to the actuator

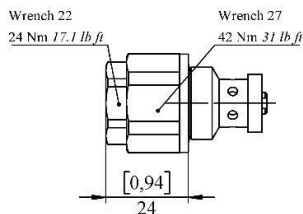

Pressure drop P-T

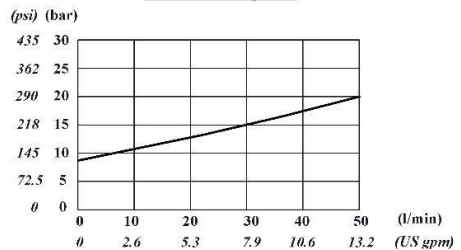

Lever control (Side A) – aluminum cap, with protection booth lever pivot box

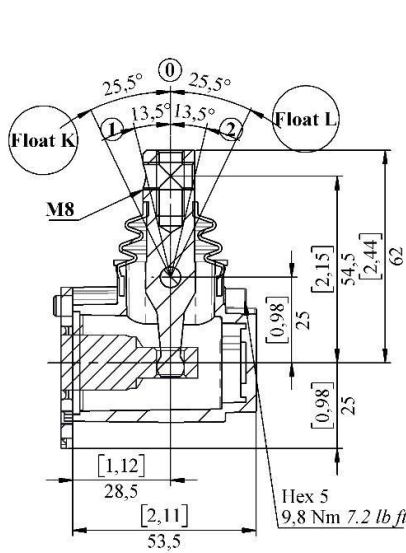

**Type KZ
& KZe**

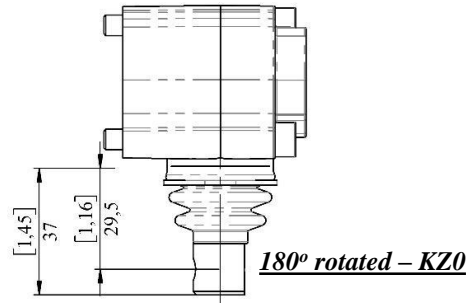
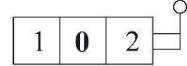

Float L & K only available in certain configuration refer to pages – 19 & 20

**Type KZ(M10)
& KZe(M10)**

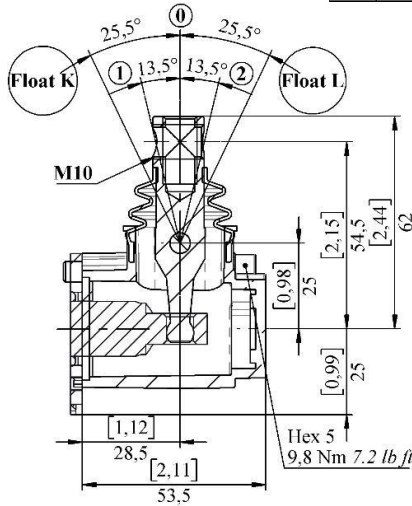
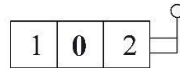

Kit KZT

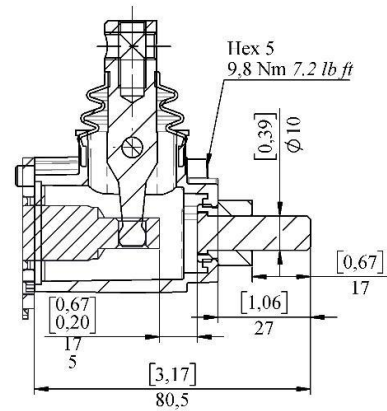
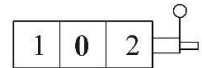

Type KI

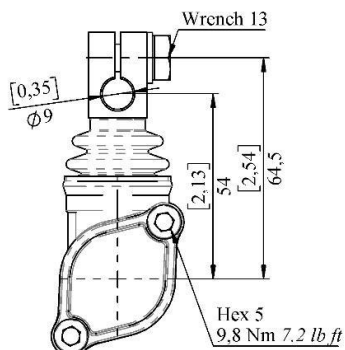
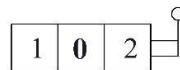

Type KY

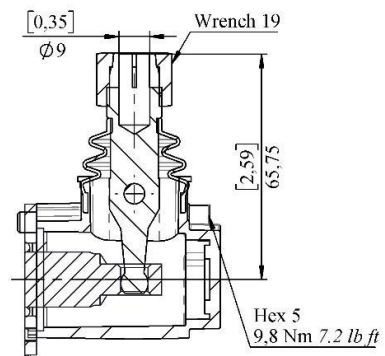
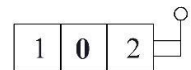

Other control arrangements (side A)

If in the order code side A is left blank, omit control type will be supplied:

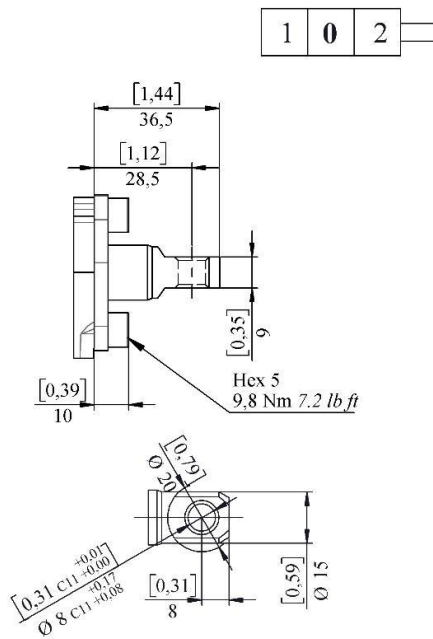

Type SLP

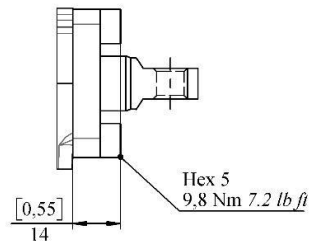

Mechanical control with dust-proof plate

Cable remote control – V1

1 0 2

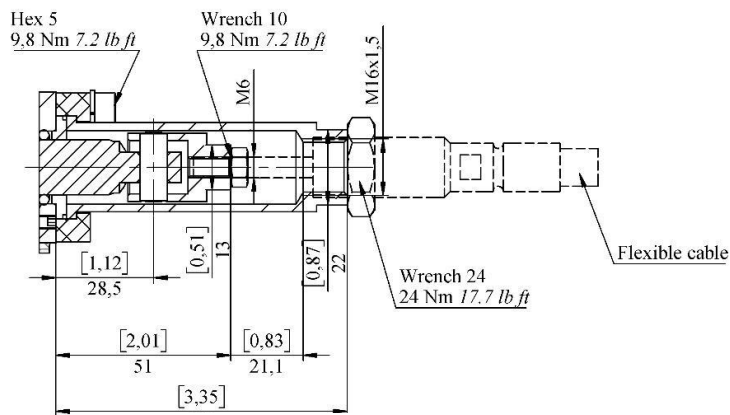

**Control valves
with V1**

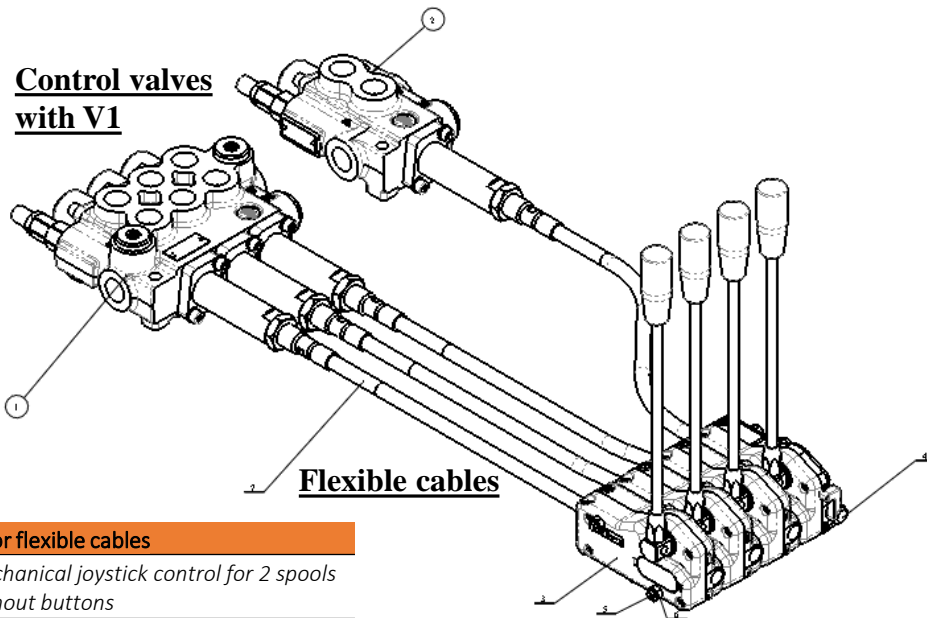

Flexible cables

Remote controls

Controls for flexible cables	
3335	Mechanical joystick control for 2 spools without buttons
3375	Mechanical joystick control for 2 spools with 1 button
6008	Mechanical joystick control for 2 spools with 2 buttons
IS 3047	Single lever control
IS 3076	Single lever control with antireverse lock
Flexible cable options code + length	
IT-731133	1.00 m
IT-731134	1.50 m
IT-731135	2.00 m
IT-731136	2.50 m
IT-731137	3.00 m
IT-731138	3.50 m
IT-731139	4.00 m

Mechanical joystick for two section control

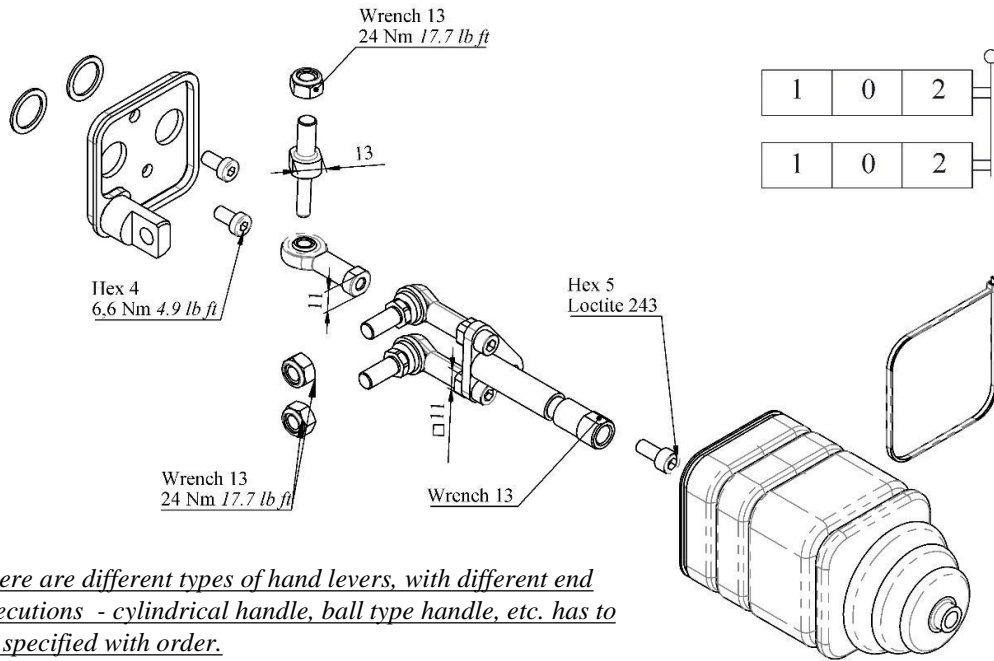

There are different types of hand levers, with different end executions - cylindrical handle, ball type handle, etc. has to be specified with order.

Type j+1

Pivot is above right

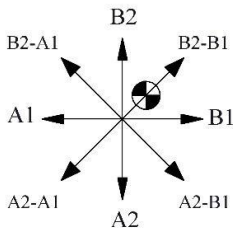

Type j+2

Pivot is above left

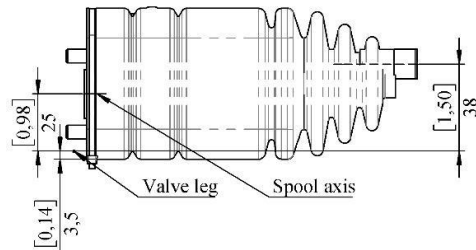
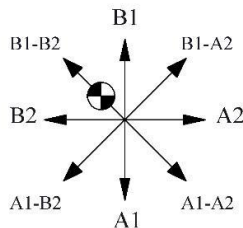

Type j+3

Pivot is bottom left

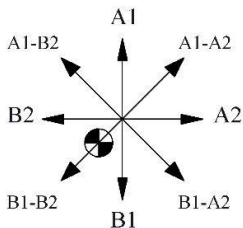

Type j+4

Pivot is bottom right

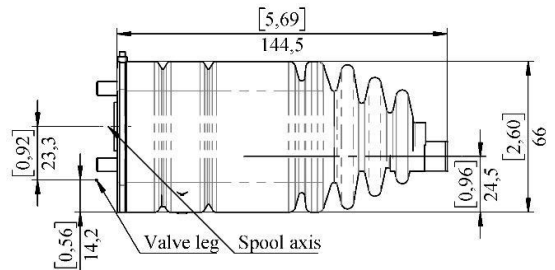
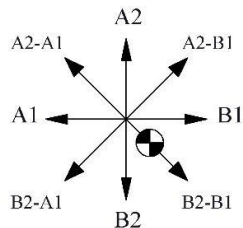

Standard hand lever dimensions

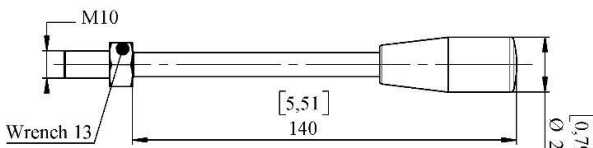

Example order code with standard lever:

02Z50/(A1A1)(ju+3)-G

alternative (same as)

02Z50/(2xA1)(ju+3)-G

Complete control – double acting ON/OFF solenoid control

Complete control – 1ESDK1

Direct control by double acting solenoid with spring return to neutral position, available for 1 to 8 spools, including 2, 3, and 4 spool valve bodies with individual check valves (both parallel and tandem version).



Electric wiring example

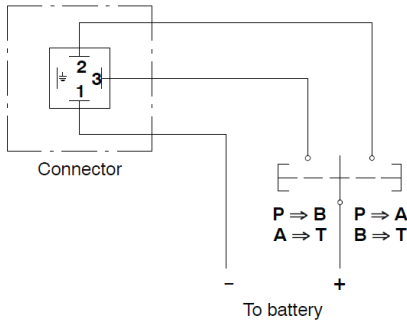

Operating features

Internal leakage (min.) A(B) to T $\Delta p = 100 \text{ bar (1450 psi)}$ fluid and valve at 40 oC (104 oF) **min. 15 cm³/min**
0.91 in³/min

COIL specifications

Nominal voltage tolerance	±10 %
Power rating	53 W
Coil insulation	Class H
Duty cycle	100%

Available spool options

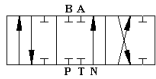

A(1ESD)

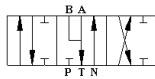

D(1ESD)

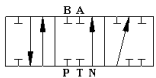

B(1ESD)

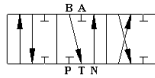

E(1ESD)

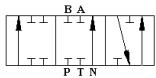

C(1ESD)

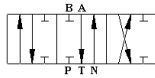

F(1ESD)

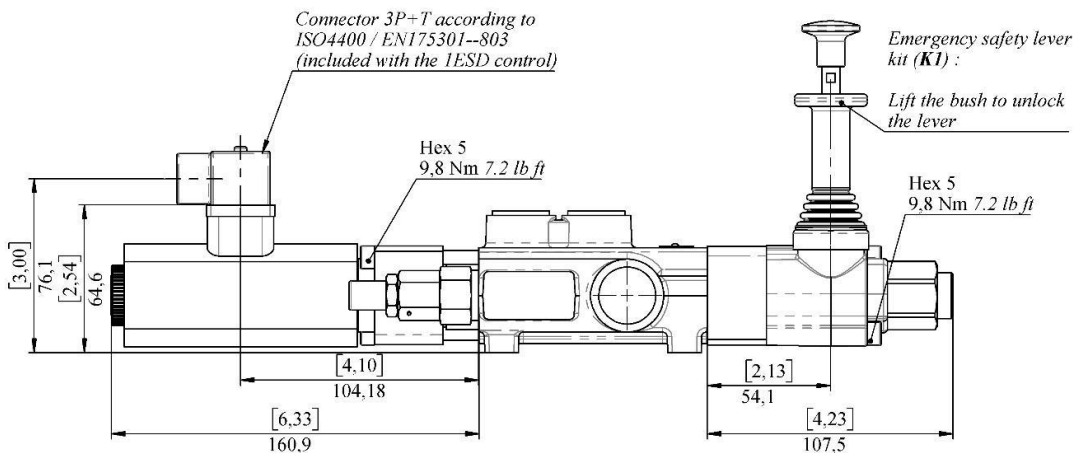

Complete control – single acting ON/OFF solenoid control

Complete control – ES3 / ES2 / ES1

Direct control by two single acting solenoid with spring return to neutral position (ES3) or one single acting solenoid (ES1 or 2); available for 1 to 8 spools, including 2, 3, and 3 spool valve bodies with individual check valves (both parallel and tandem version).

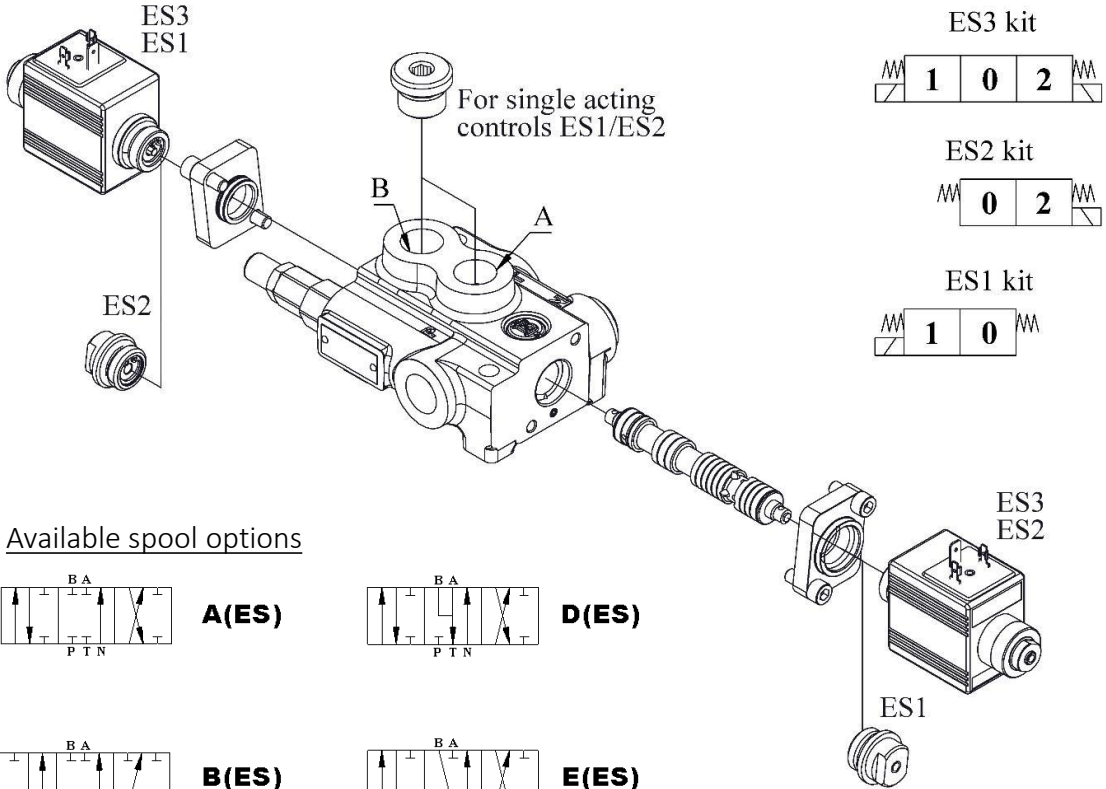

Available spool options

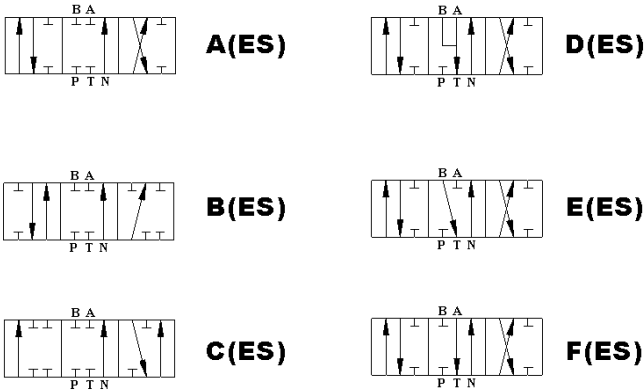

Example order code: Z50/AES3-12V-G12

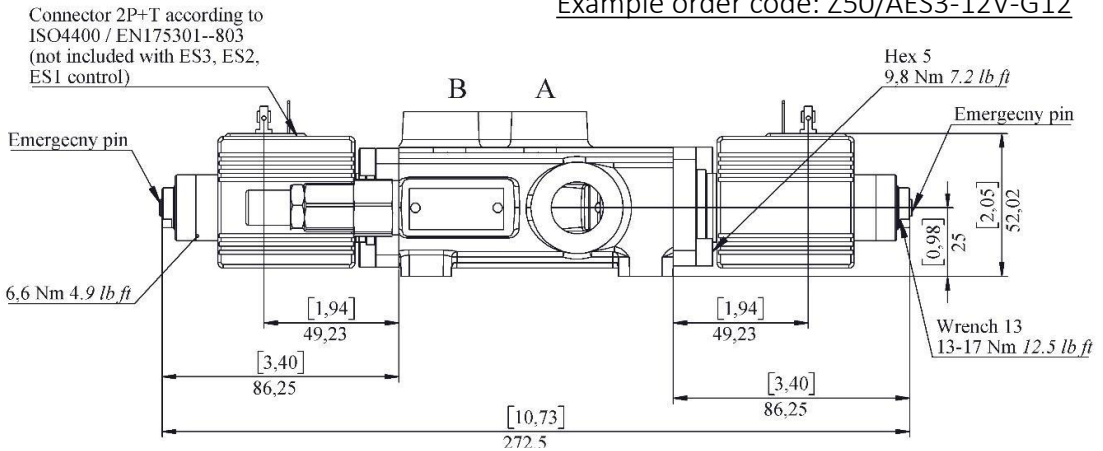

Complete control – single acting ON/OFF solenoid control

Operating conditions

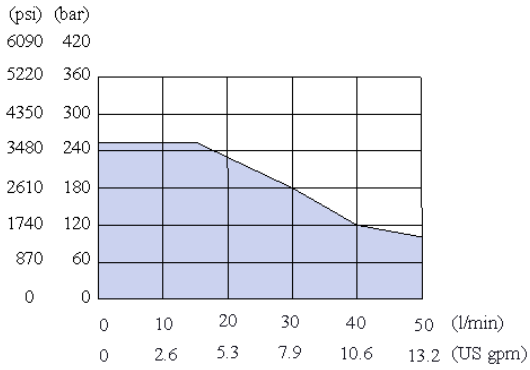

Operating features

Internal leakage (min.) A(B) to T
 $\Delta p = 100 \text{ bar (1450 psi)}$ fluid and valve at 40 oC (104 oF)
 min. 15 cm³/min
 0.91 in³/min

COIL specifications

Nominal voltage tolerance	±10 %
Power rating	36 W
Current	3 A - 12 VDC 1,5 A - 24 VDC
Weather protection	IP65
Coil insulation	Class H
Duty cycle	100%

Electric wiring example

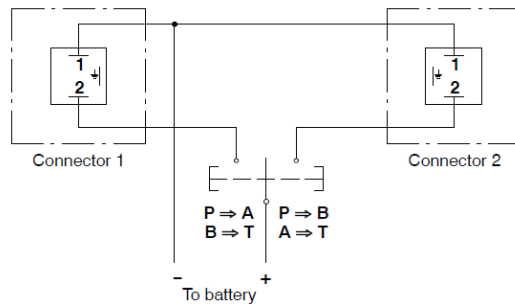

Connector specifications per type of coils available

**2P+T according to
ISO 4400 / EN175301-803**

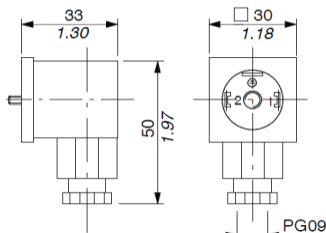

**Connector specifications
2 poles, type Deutsch DT06-2S
Male housing with female ends**

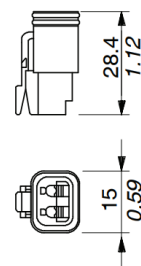

Complete control – Rotary control A26

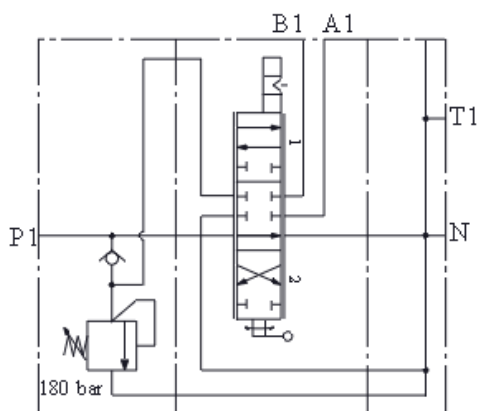
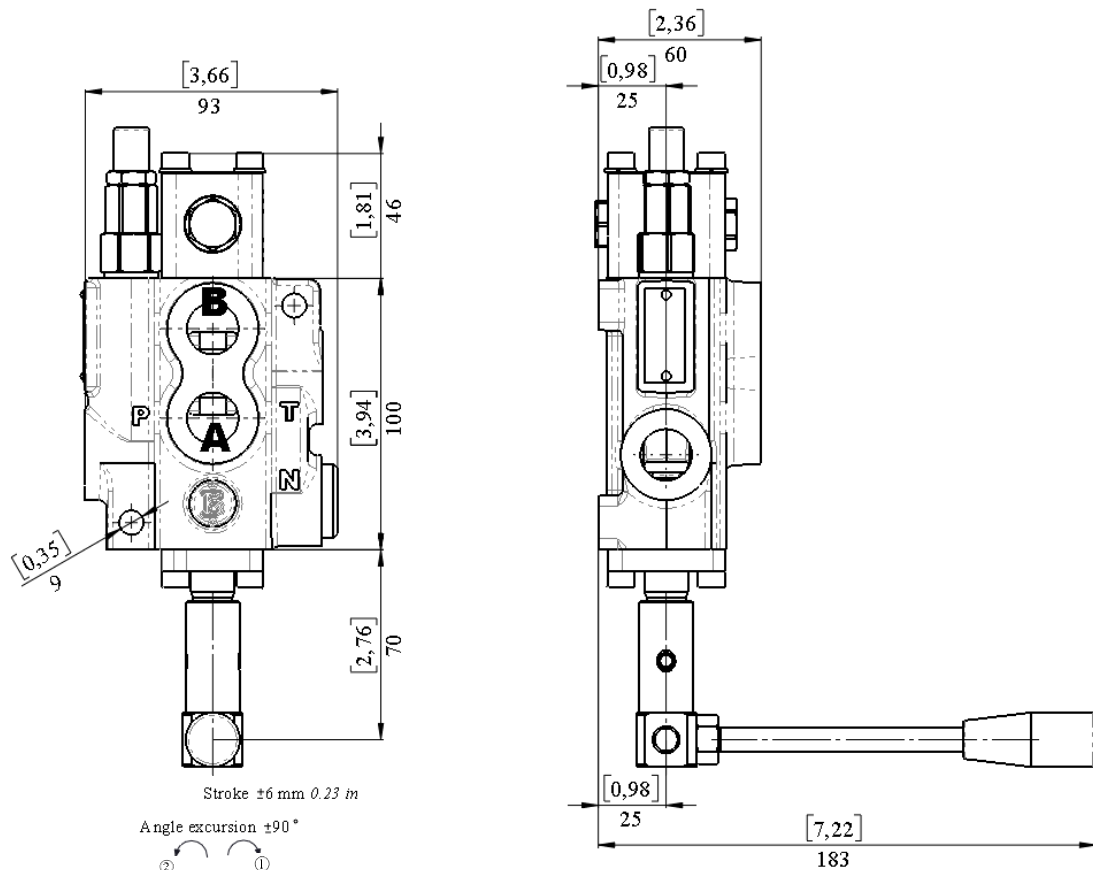

Example order code: Z50/AmL26-G

Outlet port options

It is possible to have open centre, closed centre and high pressure carry-over (power beyond)

If in the order code before the thread specification port N is plugged with standard G1/2 plug

C2 - with carry-over (high pressure carry over)

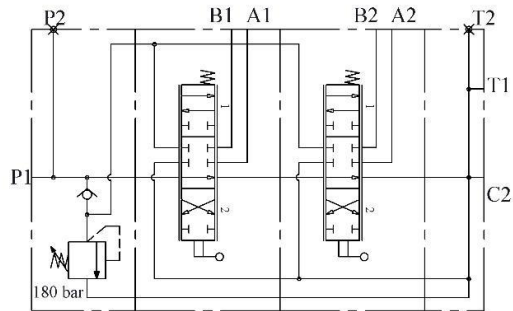
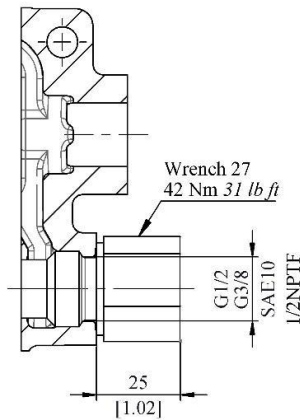

Example order code 02Z50/2x(A1KZ1)-C2-G

C – closed center

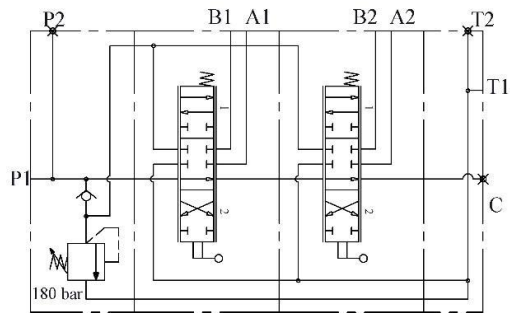
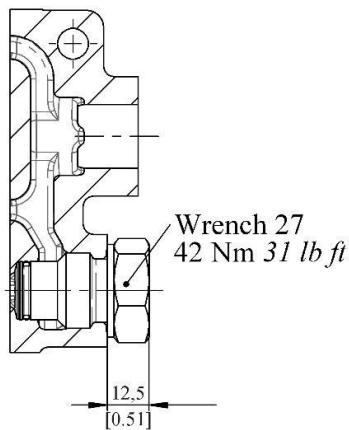

Example order code: 02Z50/2x(A1KZ1)-C-G

C2D - Direct high pressure carry-over

