

**Direct acting pressure sequence valve
Valvola di sequenza ad azione diretta**

Specifications / Specifiche

Fluid viscosity:	Viscosità Fluido :	ISO 3448
Filtration:	Classe di contaminazione:	ISO 4406
Fluid temperature:	Temperatura fluido:	-20°C +90°C
Ambient temperature:	Temperatura ambiente:	-20°C +50°C
Max. operating pressure:	Pressione di lavoro max :	350 Bar
Standard seals:	Guarnizioni standard:	NBR 70 Shore A
Manifold material:	Materiale collettore:	Zinc plated steel

Hydraulic symbol / Simbolo idraulico

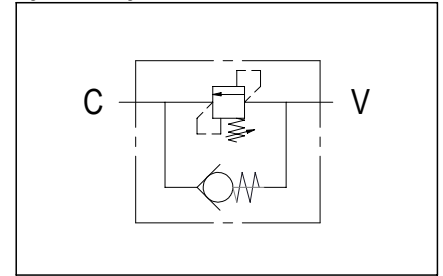

Dimensions / Dimensioni (mm)

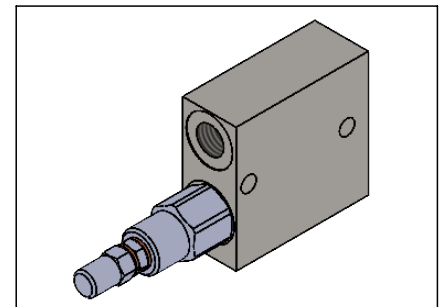
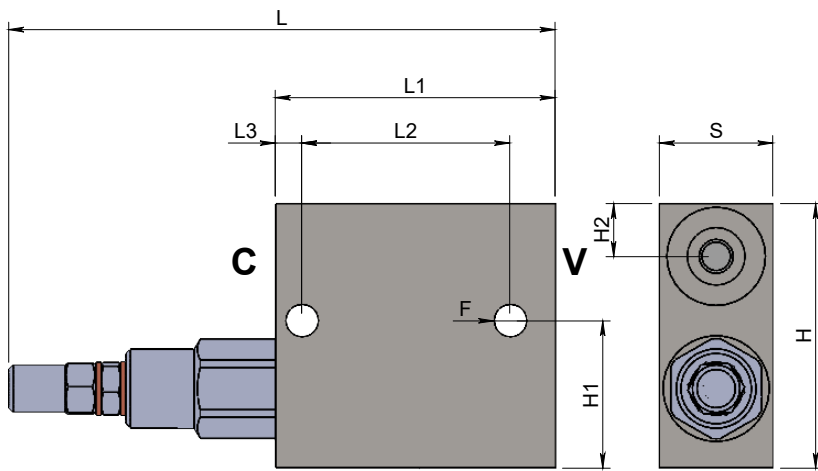

Performance / Prestazioni

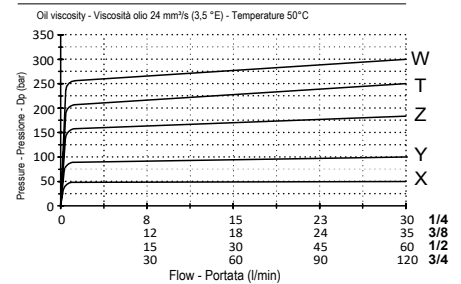

How to order / Come ordinare

11-A-03-F00-3-R--*-N1**

N= Tamper resistant cap
O= Handknob and locknut
R= Screw with steel cap (Std)

Adjustment
Regolazione

Seals material [N1= NBR (Std)
Materiale guarnizioni [V1 = Viton

02 = 1/4 BSPP
03 = 3/8 BSPP
04 = 1/2 BSPP
05 = 3/4 BSPP

Ports size
Dimensione attacchi

Setting range
Campo taratura

Std setting at 5 l/min		Std setting at 5 l/min		Std setting at 5 l/min	
1/4	3/8 - 1/2	3/8	3/4		
X = 05-50 bar	50 bar	X = 10-50 bar	30 bar	Z = 20-200 bar	160 bar
Y = 30-100 bar	100 bar	Y = 20-100 bar	75 bar	W = 50-400 bar (Std)	180 bar
Z = 50-210 bar (Std)	200 bar	Z = 10-180 bar (Std)	90 bar		
W = 100-350 bar	300 bar	T = 50-250 bar	130 bar		
		W = 80-300 bar	150 bar		

Standard code Codice standard	Thread/Filetto		L	L1	L2	L3	H	H1	H2	S	F	Weight/Peso (kg)	Max. Flow Q max (l/min)
	P	T											
11A03F003R02ZN1	1/4	1/4	120	60	49	5.5	60	24.5	12	25	6.5	0.7	30
11A03F003R03ZN1	3/8	3/8	146	74	55	7	70	39	14	30	8.5	1.2	35
11A03F003R04ZN1	1/2	1/2	152	80	55	7	70	37	15	30	8.5	1.1	70
11A03F003R05ZN1	3/4	3/4	164	100	80	10	100	50	20	40	8.5	2.8	120

*On request versions: Please, contact our customer service.

*Versioni su richiesta: Per cortesia contattare il ns. servizio clienti.