

SOLENOID DIRECTIONAL CONTROL VALVE SVV 90

SVV stackable 6 port/2 way change over valves are designed to be used when extra circuits are to be operated from one control lever on machines such as fork lift trucks, agricultural front end loader, telescopic handlers, and in transmissions circuits.

SVV can be stacked up to 3 valves allowing for the diverting of flow 2,3 or 4 directions depending on the combination chosen.

These type selector valves have been carefully designed to meet the demands of progressive machine manufacturers for cost effective, reliable circuit selectors. The valve bodies are made from a special high quality cast iron alloy which is machined, using advanced machining techniques.

They are designed for a max, working pressure of 280bar (4060 psi) and will accept flows up to 90 l/min -1/2" ported version. The advanced design of the valve spool ensures that fast spool switching can take place under any conditions without the use of a separate drain line.

The selector valves are often connected to the service ports of a double acting spool valve, to allow two double acting services to be operated from the one service.

The SVV valves can also be used to benefit circuits where the spool valves are located a long distance from the pumps. In this case the de-energized SVV valve will return both lines to tank and, when energized, feed the circuit spool valves. This provides the advantage of minimizing the pressure drop through the system when needed, such as when transporting a machine in non-operational mode.

Dimensions and options

Single section

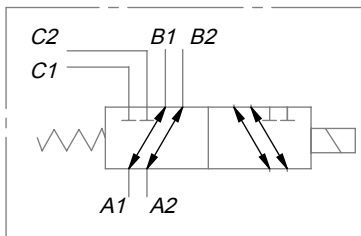
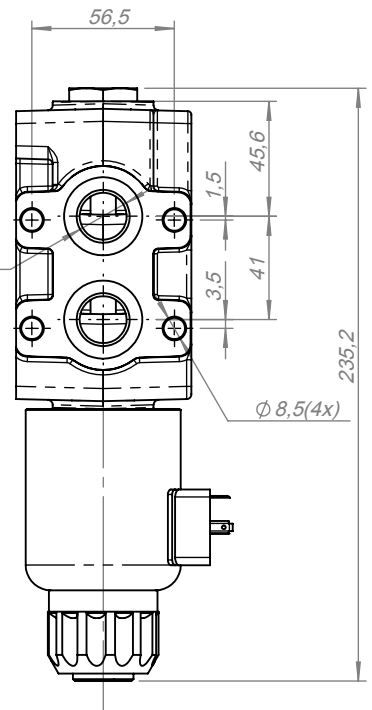
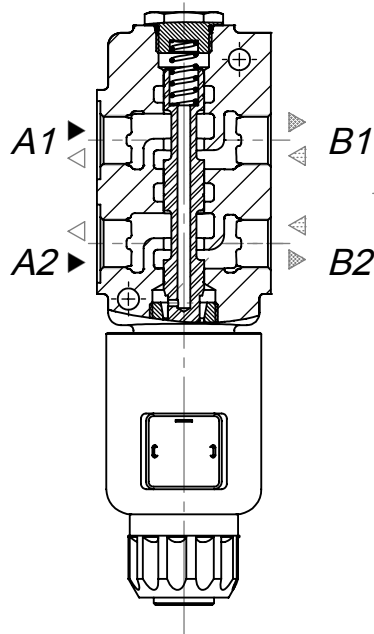
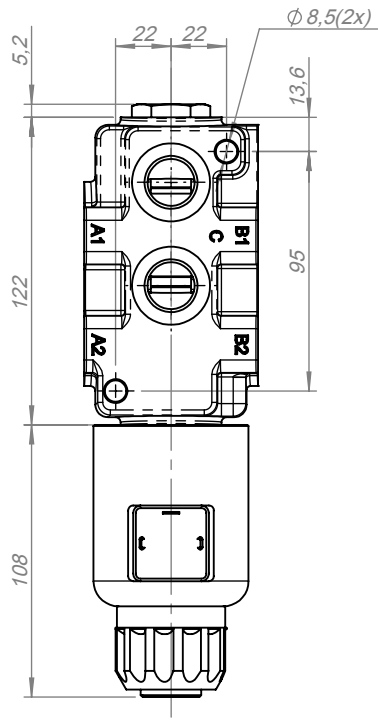
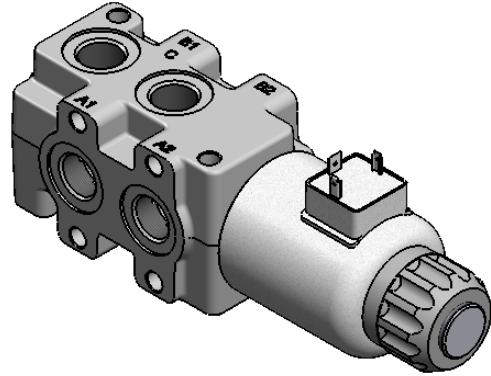
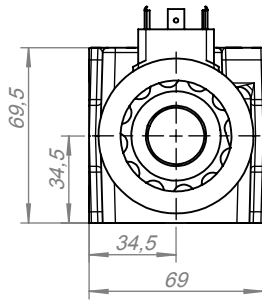

code	Threaded connections
G	A1,A2,B1,B2,C1,C2 -G1/2"
M	A1,A2,B1,B2,C1,C2 -M18X1.5
S	A1,A2,B1,B2,C1,C2 -SAE8

Flow rate	l /min	90
P	bar	250
oil temperature	C°	-20/+70
viscosity	mm ² /s	15-380
filtration NAS1638		9

Valve assembly & schematics

3 sections allowing for three extra functions

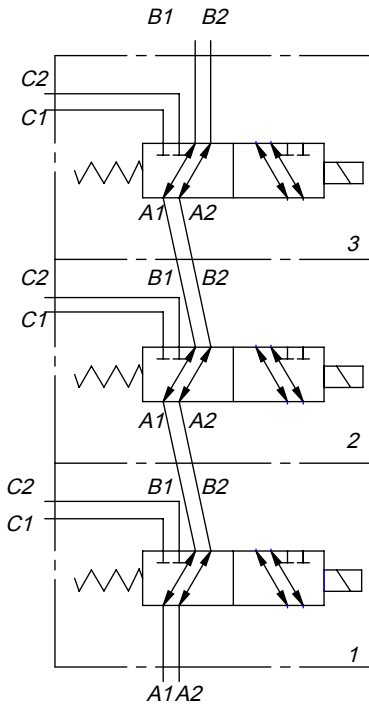
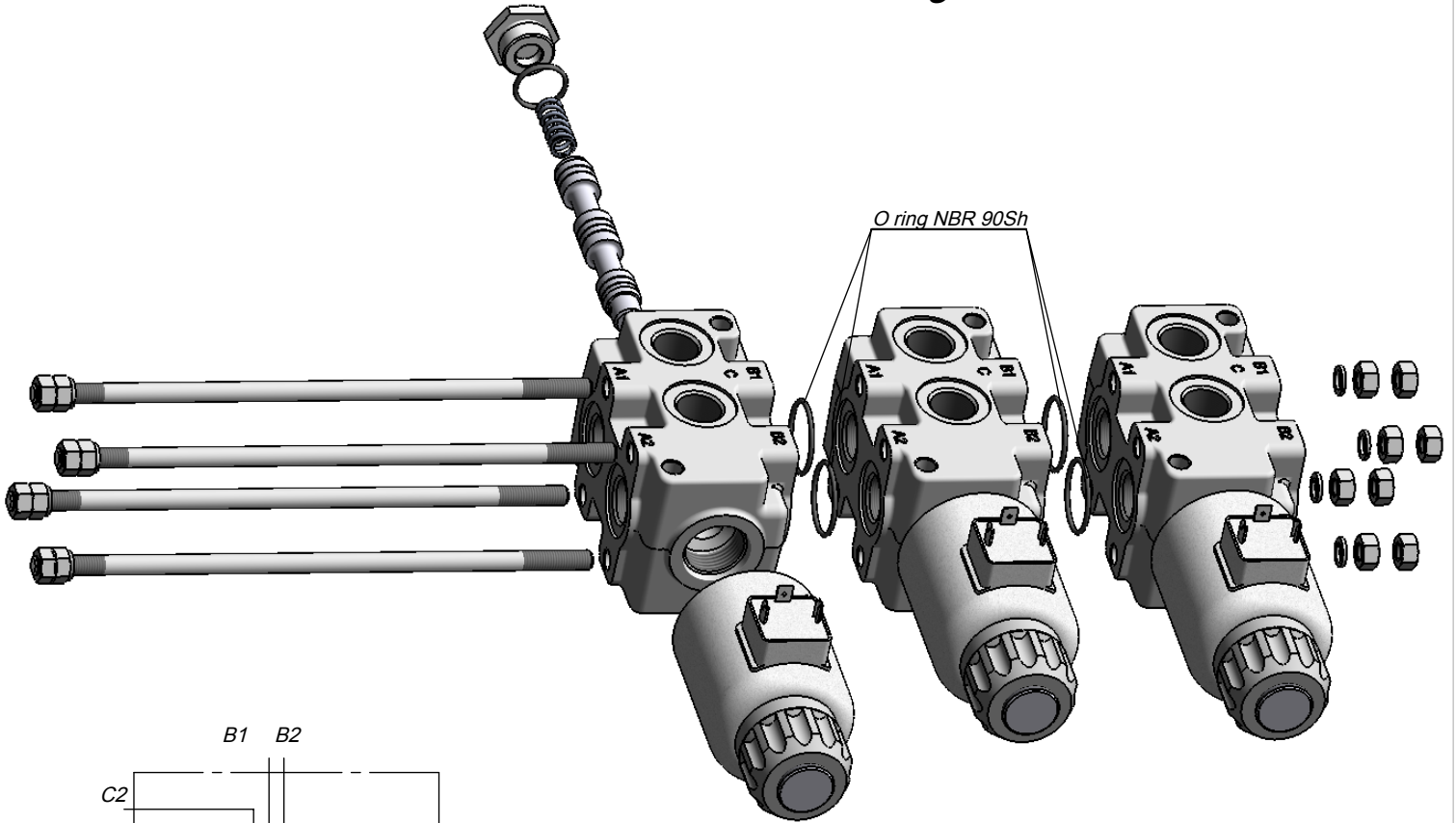

for stacking 1-3units

Ordering code :

3 SVV 6/2 - 12DC - G -

Number of valves

Ports / switching positions

Supply voltage 12V DC / 24V DC

Threaded connections

other

3SVV 6/2-12DC-G

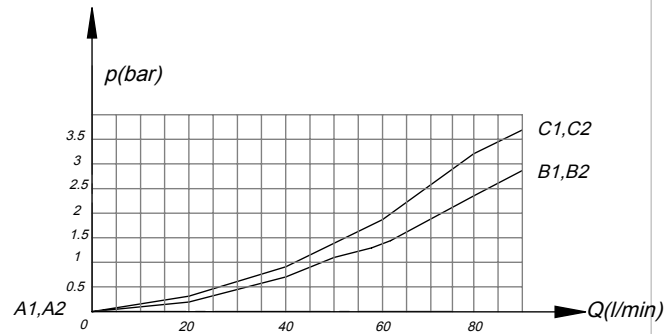
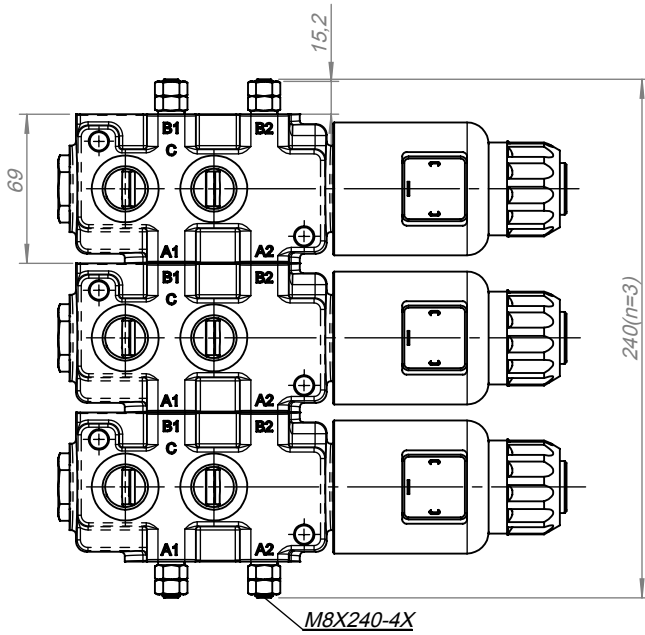
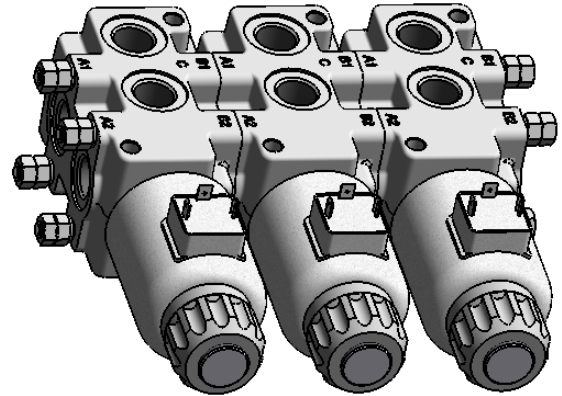
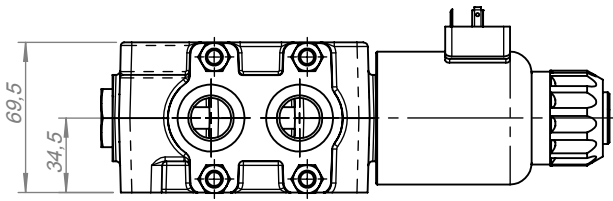

Mounting example 2SVV 6/2-...

