

İNDİRME VE KALDIRMA VALFİ | LOWERING AND TIPPING VALVE

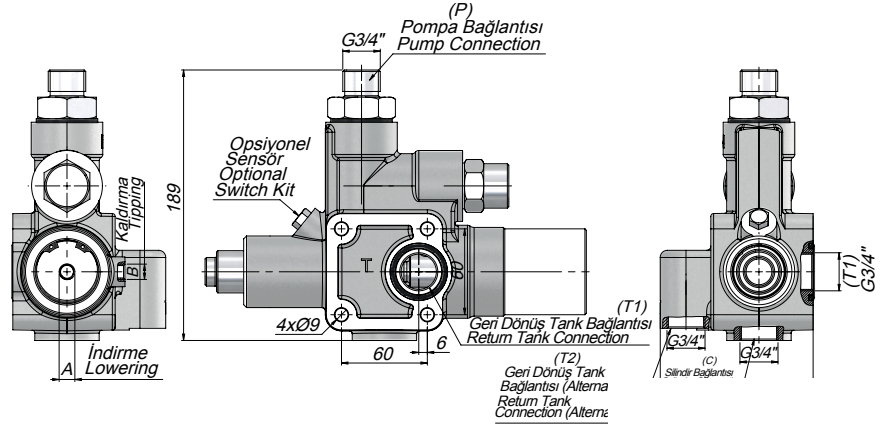

Kod Code	Debi Oranı Flow Rate	Max.Çalışma Basıncı Max.Working Pressure	Sıvı Sıcaklığı Fluid Temperature	Çalışma Vizkosite Seviyesi Operating Viscosity Range	Havali Çalışma Basıncı Pneumatic Working Pressure
	(l/dk)	(Bar)	(°C)	(cSt)	(Bar)
VSL150	150	280	-10 ~+80~	-12-100 cSt	7-12

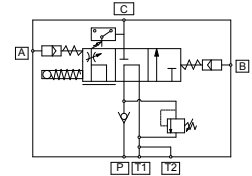

HİDROLİK SEMBOL  
HYDRAULIC SYMBOL