

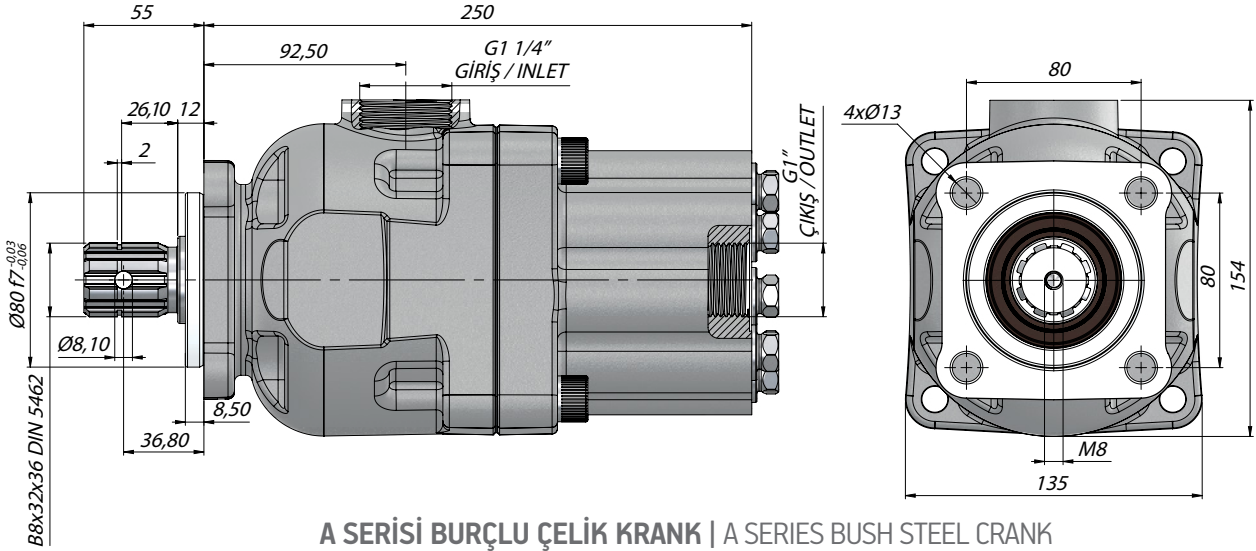

PISTON  
PUMP



**A SERİSİ BURÇLU ÇELİK KRANK | A SERIES BUSH STEEL CRANK**

Kod Code	İletim Hacmi Displacement	Maks.Sürekli Basınç Max.Continuous Pressure	Min. Hız Min.Speed	Maks.Sürekli Hız Max.Continuous Speed
	(cm <sup>3</sup> /rev)	(100%)(BAR)	(RPM)	(RPM)
P0960SF131A	60	270	300	1500
P0980SF131A	80			

**B SERİSİ RULMANLI DÖKÜM KRANK | B SERIES BEARING CASTING CRANK**

Kod Code	İletim Hacmi Displacement	Maks.Sürekli Basınç Max.Continuous Pressure	Min. Hız Min.Speed	Maks.Sürekli Hız Max.Continuous Speed
	(cm <sup>3</sup> /rev)	(100%)(BAR)	(RPM)	(RPM)
P0960SF131B	60	270	300	1500
P0980SF131B	80			

**C SERİSİ RULMANLI ÇELİK KRANK | C SERIES BEARING STEEL CRANK**

Kod Code	İletim Hacmi Displacement	Maks.Sürekli Basınç Max.Continuous Pressure	Min. Hız Min.Speed	Maks.Sürekli Hız Max.Continuous Speed
	(cm <sup>3</sup> /rev)	(100%)(BAR)	(RPM)	(RPM)
P0960SF131C	60	270	300	1500
P0980SF131C	80			