

TEKNİK VERİLER | TECHNICAL DATA

2+4 DELİKLİ SAE C KAMALI DİŞLİ MOTOR | 2+4 HOLES SAE C KEYED GEAR MOTOR

Giriş Basıncı Inlet Pressure		0.3÷ 2 bar	
Çalışma Viskozite Seviyesi Operating Viscosity Range		-12:100 cSt	
Sıvı Sıcaklığı Fluid Temperature		-40 °C+145 °C	
Çalışma Basıncı Working Pressure	Kirlilik Contamination		Filtre Filter
	NAS 1638	ISO 4406	$\beta_x=75$
≥200 bar	11	20/17	25 μ m
≤200 bar	12	21/18	40 μ m

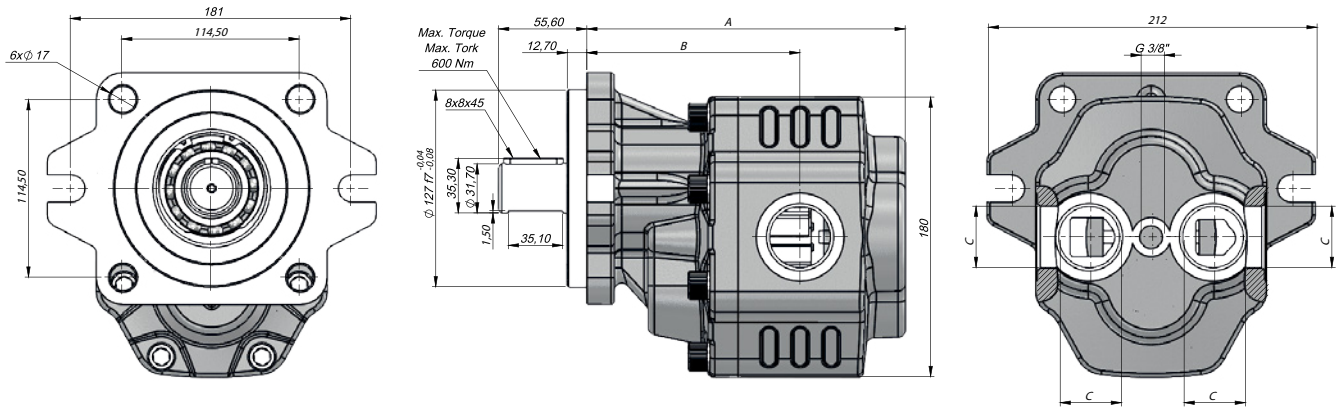

Kod Code	İletim Hacmi Displacement	Maks.Sürekli Basınç Max.Continuous Pressure	Min. Hız Min.Speed	Maks.Sürekli Hız Max.Continuous Speed	A	B	Giriş Inlet	Çıkış Outlet
BD	(cm ³ /rev)	(100%)(BAR)	(RPM)	(RPM)	(mm)	(mm)	C	C
GM40063CK1135	63	290	300	1800	188,5	127,5	G1"	C
GM40073CK1135	73	280			192,5	127,5		
GM40087CK1135	87	260			197,5	131,5		
GM40109CK1135	109	250		1500	205,5	137,5	G1 1/4"	C
GM40116CK1135	116	240			205,5	137,5		
GM40133CK1135	133	220			214,5	138,5		
GM40151CK1135	151	180			220,5	141		