

4 DELİKLİ ASAE-L ÇİFT YÖNLÜ DİŞLİ MOTOR | 4 HOLES ASAE-L BI-DIRECTIONAL GEAR MOTOR

Giriş Basıncı Inlet Pressure	0.3÷ 2 bar		
Çalışma Viskozite Seviyesi Operating Viscosity Range	-12:100 cSt		
Sıvı Sıcaklığı Fluid Temperature	-40 °C+145 °C		
Çalışma Basıncı Working Pressure	Kirlilik Contamination		Filtre Filter
	NAS 1638	ISO 4406	$\beta_x=75$
≥200 bar	11	20/17	25 μ m
≤200 bar	12	21/18	40 μ m

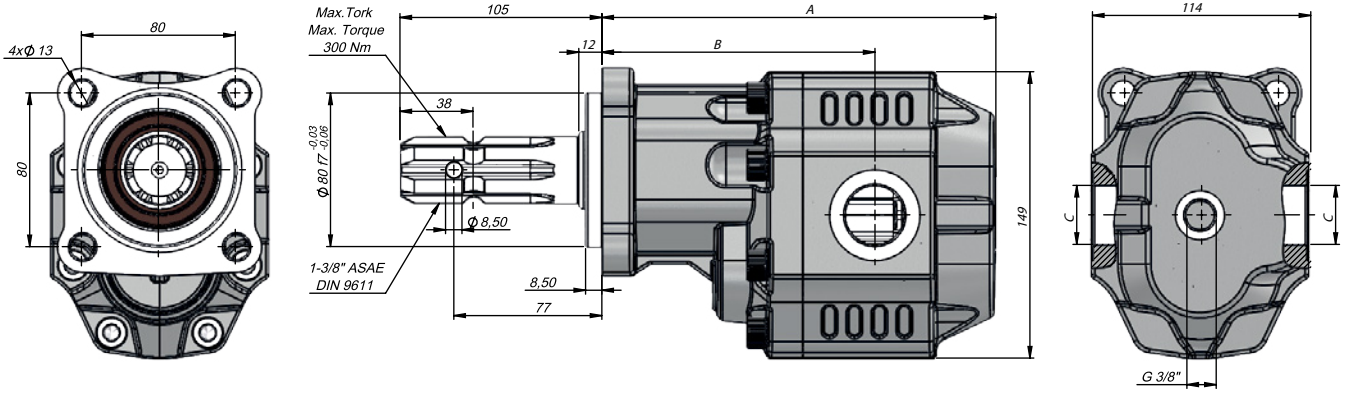

Kod Code	İletim Hacmi Displacement	Maks.Sürekli Basınç Max.Continuous Pressure	Min. Hız Min.Speed	Maks.Sürekli Hız Max.Continuous Speed	A	B	Giriş Inlet	Çıkış Outlet
BD	(cm ³ /rev)	(100%)(BAR)	(RPM)	(RPM)	(mm)	(mm)	C	C
GM30017SF831	17	300	300	2500	171,5	124,5	G1/2"	G1/2"
GM30027SF831	27	290			177,5	129,5		
GM30034SF831	34	285		2000	182,5	130,5	G3/4"	G3/4"
GM30043SF831	43	280			188,5	135,5		
GM30051SF831	51	230		1800	193,5	135,5	G1"	G1"
GM30061SF831	61	225			201,5	142		
GM30073SF831	73	215		1600	211	144	G1"	G1"
GM30082SF831	82	200			212,5	146		
GM30100SF831	100	190		1500	225,5	160	G1 1/4"	G1 1/4"
GM30125SF831	125	170			241,5	164		