

## TEKNİK VERİLER | TECHNICAL DATA

### 4 DELİKLİ ASAE-S ÇİFT YÖNLÜ DİŞLİ MOTOR | 4 HOLES ASAE-S BI-DIRECTIONAL GEAR MOTOR

Giriş Basıncı   Inlet Pressure		0.3÷ 2 bar	
Çalışma Viskozite Seviyesi   Operating Viscosity Range		-12:100 cSt	
Sıvı Sıcaklığı   Fluid Temperature		-40 °C+145 °C	
Çalışma Basıncı   Working Pressure	Kirlilik   Contamination		Filtre   Filter
	NAS 1638	ISO 4406	$\beta_x=75$
$\geq 200$ bar	11	20/17	25 $\mu$ m
$\leq 200$ bar	12	21/18	40 $\mu$ m

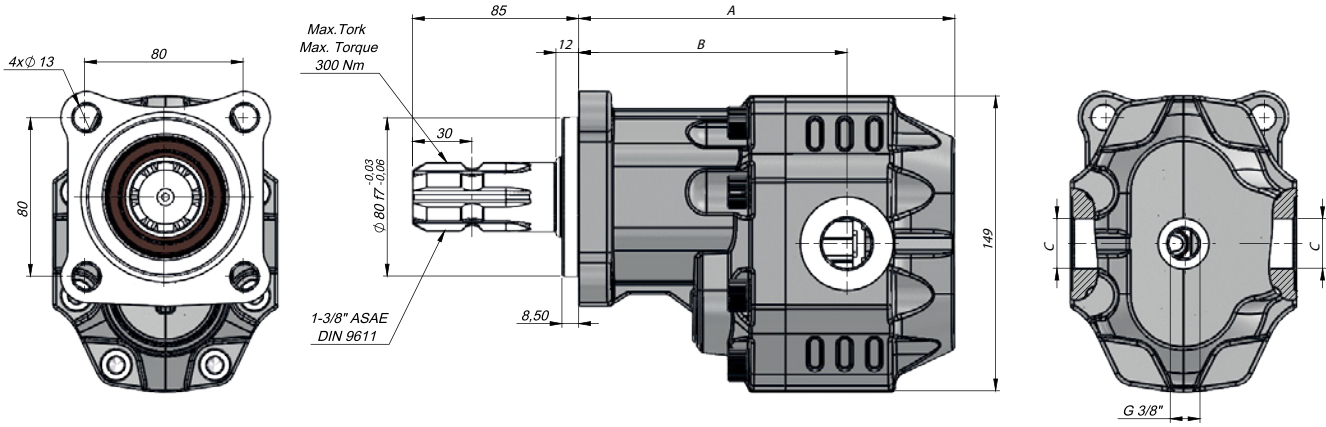

Kod Code	İletim Hacmi Displacement	Maks.Sürekli Basınc Max.Continuous Pressure	Min. Hız Min.Speed	Maks.Sürekli Hız Max.Continuous Speed	A	B	Giriş Inlet	Çıkış Outlet	
BD	(cm <sup>3</sup> /rev)	(100%)(BAR)	(RPM)	(RPM)	(mm)	(mm)	C	C	
GM30017SF231	17	300	300	2500	171,5	124,5	G1/2"	G1/2"	
GM30027SF231	27	290			177,5	129,5			
GM30034SF231	34	285		2000	182,5	130,5	G3/4"	G3/4"	
GM30043SF231	43	280			188,5	135,5			
GM30051SF231	51	230		1800	193,5	135,5	G1"	G1"	
GM30061SF231	61	225			201,5	142			
GM30073SF231	73	215		1600	211	144	G1"	G1"	
GM30082SF231	82	200			212,5	146			
GM30100SF231	100	190		1500	241,5	225,5	160	G1	G1
GM30125SF231	125	170				241,5	164	G1 1/4"	G1 1/4"