

TEKNİK VERİLER | TECHNICAL DATA

2+4 DELİKLİ SAE B 15 DİŞ ÇİFT YÖNLÜ DİŞLİ MOTOR
2+4 HOLES SAE B 15 TEETH BI-DIRECTIONAL GEAR MOTOR

Giriş Basıncı Inlet Pressure	0.3÷ 2 bar		
Çalışma Viskozite Seviyesi Operating Viscosity Range	-12:100 cSt		
Sıvı Sıcaklığı Fluid Temperature	-40 °C+145 °C		
Çalışma Basıncı Working Pressure	Kirlilik Contamination		Filtre Filter
	NAS 1638	ISO 4406	$\beta_x=75$
≥ 200 bar	11	20/17	25 μm
≤ 200 bar	12	21/18	40 μm

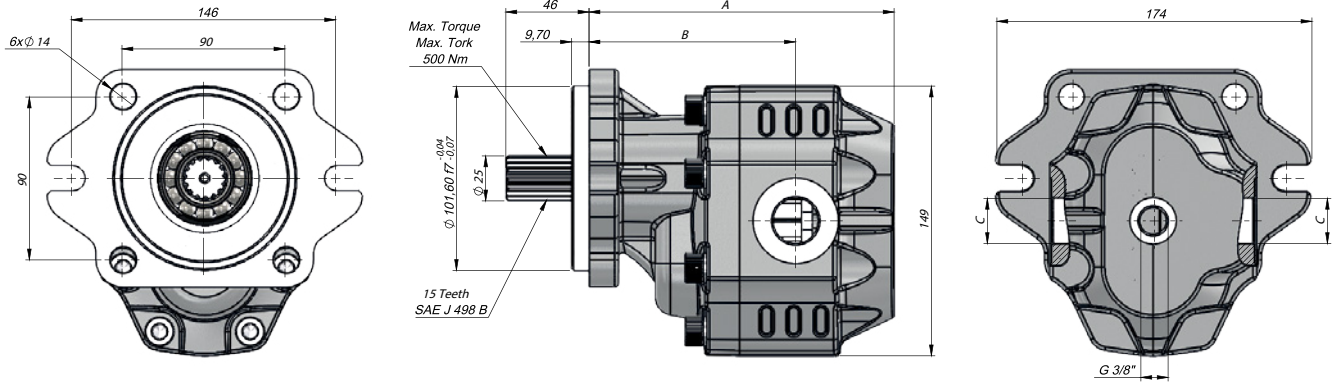

Kod Code	İletim Hacmi Displacement	Maks.Sürekli Basınç Max.Continuous Pressure	Min. Hız Min.Speed	Maks.Sürekli Hız Max.Continuous Speed	A	B	Giriş Inlet	Çıkış Outlet
BD	(cm ³ /rev)	(100%)(BAR)	(RPM)	(RPM)	(mm)	(mm)	C	C
GM30017BF631	17	300	300	2500	150	103	G1/2"	G1/2"
GM30027BF631	27	290			156	108		
GM30034BF631	34	285		2000	161	109	G3/4"	G3/4"
GM30043BF631	43	280			167	114		
GM30051BF631	51	230		1800	172	114	G1"	G1"
GM30061BF631	61	225			180	120,5		
GM30073BF631	73	215		1600	192,5	122,5	G1"	G1"
GM30082BF631	82	200			191	124,5		
GM30100BF631	100	190		1500	204	138,5	G1 1/4"	G1 1/4"
GM30125BF631	125	170			220	142,5		