

## TEKNİK VERİLER | TECHNICAL DATA

### 4 DELİKLİ ISO DİŞLİ MOTOR | 4 HOLES ISO GEAR MOTOR

Giriş Basıncı   Inlet Pressure		0.3÷ 2 bar	
Çalışma Viskozite Seviyesi   Operating Viscosity Range		-12:100 cSt	
Sıvı Sıcaklığı   Fluid Temperature		-40 °C+145 °C	
Çalışma Basıncı   Working Pressure	Kirlilik   Contamination		Filtre   Filter
	NAS 1638	ISO 4406	$\beta_x=75$
≥200 bar	11	20/17	25 $\mu$ m
≤200 bar	12	21/18	40 $\mu$ m

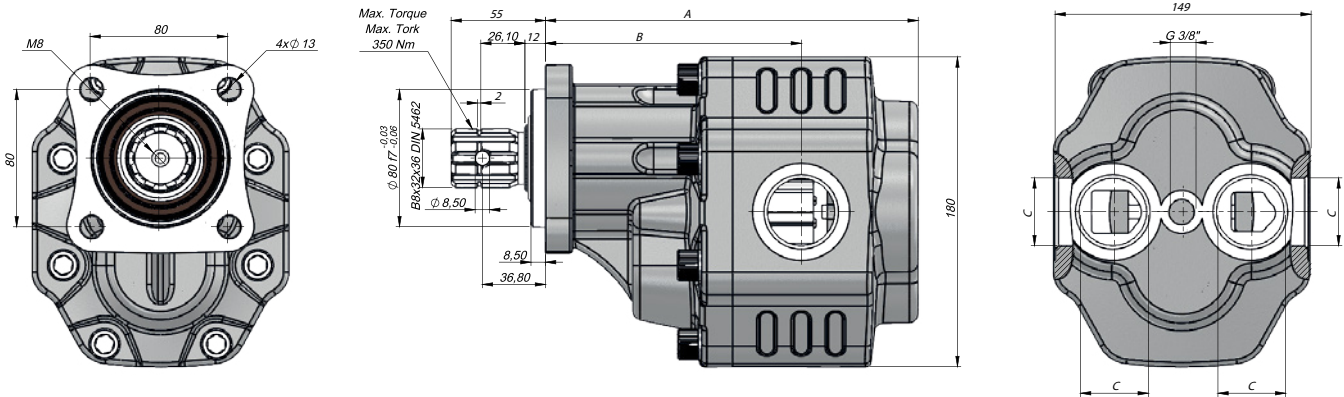

Kod Code	İletim Hacmi Displacement	Maks.Sürekli Basınç Max.Continuous Pressure	Min. Hız Min.Speed	Maks.Sürekli Hız Max.Continuous Speed	A	B	Giriş Inlet	Çıkış Outlet
BD	(cm <sup>3</sup> /rev)	(100%)(BAR)	(RPM)	(RPM)	(mm)	(mm)	C	C
GM40063SF135	63	290	300	1800	200	139	G1"	C
GM40073SF135	73	280			204	139		
GM40087SF135	87	260			209	144		
GM40109SF135	109	250		1500	G1 1/4"	217	149	C
GM40116SF135	116	240				217	149	
GM40133SF135	133	220				226	150	
GM40151SF135	151	180			232	153		